



Review

Impacts of Vehicle-to-Everything Enabled Applications: Literature Review of Existing Studies

Jianhe Du¹, Kyoungho Ahn¹, Mohamed Farag^{1,2} and Hesham A. Rakha^{1,3,*}

¹ Virginia Tech Transportation Institute, 3500 Transportation Research Plaza, Blacksburg, VA 24061, USA

² College of Computing and Information Technology, Arab Academy for Science, Technology, and Maritime Transport, Giza, Governorate 3650111, Egypt

³ Department of Civil Engineering, Virginia Tech, Blacksburg, VA 24061, USA

E-mail: hrakha@vt.edu

Received: 30 October 2022; **Revised:** 9 January 2023; **Accepted:** 11 January 2023

Abstract: As communication technology is developing at a rapid pace, connected vehicles (CVs) can potentially enhance vehicle safety while reducing vehicle energy consumption and emissions via data sharing. Many researchers have attempted to quantify the impacts of such CV applications and vehicle-to-everything (V2X) communication, or the instant and accurate communication among vehicles, devices, pedestrians, infrastructure, network, cloud, and grid. Cellular V2X (C-V2X) has gained interest as an efficient method for this data sharing. In releases 14 and 15, C-V2X uses 4G LTE technology, and in release 16, it uses the latest 5G new radio (NR) technology. Among its benefits, C-V2X can function even with no network infrastructure coverage; in addition, C-V2X surpasses older technologies in terms of communication range, latency, and data rates. Highly efficient information interchange in a CV environment can provide timely data to enhance the transportation system's capacity, and it can support applications that improve vehicle safety and minimize negative impacts on the environment. Achieving the full benefits of CVs requires rigorous investigation into the effectiveness, strengths, and weaknesses of different CV applications. It also calls for deeper understanding of the communication protocols, results with different CV market penetration rates (MPRs), CV- and human-driven vehicle interactions, integration of multiple applications, and errors and latencies associated with data communication. This paper includes a review of existing literature on the safety, mobility, and environmental impacts of CV applications; gaps in current CV research; and recommended directions for future research. The results of this paper will help shape future research for CV applications to realize their full potential.

Keywords: V2X, connected vehicles, communication, environmental, safety, transportation

1. Introduction

The transportation system is growing rapidly, with 276 million currently registered vehicles, a total of 4.17 million miles of highways, and 3.23 trillion vehicle miles traveled (VMT) [1]. Because of the large number of vehicles and associated traffic delays, this gigantic system operates with a significant impact on the environment and traffic safety. According to *Forbes*, Americans lost nearly 99 hours in 2019, or an average of \$1,377 per person, due to traffic crashes [2]. In addition, at least 38,800 people were killed in motor vehicle collisions [3]. Most of these crashes were caused by human errors, such as distraction, driver inexperience, drowsiness, or speeding, all of which may be mostly avoided if drivers could receive warnings ahead of time. A report released by INRIX found that the economic impact of traffic congestion is both broad and complicated. In 2019, congestion cost New York \$11 billion, Los Angeles \$8.2 billion, and Chicago \$7.6 billion [4]. Safety and efficiency are not the only concerns regarding the traffic system; environmental impact has also become a major

Copyright ©2023 Jianhe Du, et al.

DOI: <https://doi.org/10.37256/cnc.1120232115>

This is an open-access article distributed under a CC BY license
(Creative Commons Attribution 4.0 International License)

<https://creativecommons.org/licenses/by/4.0/>

issue following the realization that climate change is caused by human activity. The U.S. Environmental Protection Agency (EPA) published the *Inventory of U.S. Greenhouse Gas Emissions and Sinks* in April 2021 summarizing trends in U.S. greenhouse gas emissions from 1990 to 2019 [5]. The annual report identified the U.S.'s primary greenhouse gas emission sources and demonstrated that the transportation sector was responsible for the largest share at 29%. The report also mentioned that petroleum-based transportation fuel, including gasoline and diesel, is responsible for over 90% of the transportation sector's total fuel consumption. Total transportation emissions increased from 1990 to 2019 due to increased travel demand. In particular, the total VMT increased by 48% in the U.S. during that period due to economic growth, population increases, periods of low fuel prices, and increases in urban sprawl [6]. The EPA recommends reducing transportation-related emissions by switching to alternative fuel sources; leveraging advanced technologies, materials, and design to improve fuel efficiency; refining operating practices; and decreasing travel demands.

Connected vehicles (CVs) are equipped with technology that enables them to connect with not only other vehicles, but also roadway infrastructure, pedestrians, bicycle riders, and other devices through advanced wireless communication. Such technology can improve roadway safety, travel efficiency, and energy efficiency while reducing vehicle emissions. CV applications can increase throughput and mobility and, by preventing human errors, may also reduce vehicle crashes. We expect that CV technology will significantly increase the transportation system's mobility and safety in addition to lowering greenhouse gas emissions via advanced technologies and improved transportation operational practices.

Vehicle-to-everything (V2X) technology enables a vehicle to communicate with any object capable of communicating with a CV. The seven types of vehicle connectivity [7] include vehicle-to-infrastructure (V2I), vehicle-to-vehicle (V2V), vehicle-to-pedestrian (V2P), vehicle-to-network (V2N), vehicle-to-device (V2D), vehicle-to-cloud (V2C), and vehicle-to-grid (V2G). Collectively these are known as V2X. V2I is a communication protocol that allows the vehicle to communicate bidirectionally with the road infrastructure. With V2V, equipped vehicles exchange real-time data with other equipped vehicles. V2N allows vehicles to communicate with the network, including the V2X management system. V2C enables equipped vehicles to offer bidirectional data exchange with the cloud, including digital assistants and the Internet of Things. V2P includes communication with road users, including pedestrians, people using wheelchairs, people riding bicycles, and people using other mobility devices. V2D allows information exchange for equipped vehicles with any smart device such as smartphones, tablets, and other wearable devices. V2G involves communication with the smart electric grid. It should be noted that even though V2X technology includes these seven types of connectivity, most studies have focused on CV applications that are based on V2I and V2V communication.

The goal of the study is to synthesize the literature on the overall impacts of cellular V2X (C-V2X) enabled applications on the transportation system's energy consumption, efficiency, and safety. This effort's contributions are as follows: (1) while several studies investigated the benefits of C-V2X enabled applications, these studies focused on individual applications. This is the first effort to systematically summarize the potential efficiency, energy, environmental, and safety benefits of various C-V2X enabled applications and compare their performance; and (2) the study identifies shortcomings in current CV research and recommends directions for further research.

While there are several studies that have reviewed C-V2X applications, none of these studies systematically reviewed and compared the impacts of these C-V2X applications in terms of safety, environment, and mobility. The novelty of this paper is that it systematically investigates C-V2X application benefits at the network, freeway, non-signalized, and signalized arterial levels, with and without considering the communication system constraints. Previous C-V2X studies focused on the benefits of single applications without comparing various connected automated vehicle (CAV) applications and test environments.

The potential C-V2X benefits can vary based on the application type, study design, vehicle type, test location or network type, utilized energy/emission model, and market penetration rates (MPRs) of CVs. The conclusions drawn by these previous studies confirmed that, through efficient information exchange between vehicles, infrastructures, networks, devices, and other participating elements, the transportation system can operate more efficiently and with reduced emissions. CVs and C-V2X enabled applications, by providing driving directions, speed advice, and acceleration or deceleration suggestions, can help reduce delays, increase vehicle throughput, reduce greenhouse gas emissions, and improve fuel and energy efficiency, while simultaneously achieving a notable decrease in vehicle crashes. Such benefits can be significant when the MPR of CVs reaches a certain level. Furthermore, not only do CVs benefit from V2X communications, but other non-connected vehicles also benefit from the CVs' improved efficiency, safety, and decreased emissions because the transportation system has more redundancy for non-connected vehicles when CVs use the system more safely and efficiently. Figure 1 provides a graphical illustration of the C-V2X concepts.

This paper categorized previous CV studies into three areas: 1) applications ignoring communication system constraints; 2) applications modeling the mutual dependencies of the transportation and communication systems; and 3) applications considering communication system constraints. In the first category, researchers concentrated on modeling CV application benefits and impacts with the assumption that communication between vehicles and infrastructures is essentially perfect and free of any delays or errors. In addition, researchers assumed the drivers of the CVs fully followed the guidance or suggestions provided by the CV applications. The benefits of CVs typically were maximized in this category of studies. Some of the previous studies did evaluate different MPRs for CVs and the interaction of CVs and traditional vehicles. The modeling methodology in this category requires further development to accommodate compound effects generated by imperfections in the communication system. The second category includes research efforts that integrate transportation and communication system modeling in the evaluation of CV applications to account for communication system constraints. There were very few studies available in this category. Because both components of C-V2X—the wireless communication in a big data environment and the technology of connected vehicles—are still in the rapid development stage, researchers have yet to focus on the resulting interaction between these two building blocks. Instead, existing studies mostly still concentrate on one of the two fields. Most researchers in this category used traditional communication simulators with implementation support for the dedicated short-range communications (DSRC) and long-term evolution (LTE) C-V2X communication protocols. Although these simulators facilitate performance evaluation for new communication technologies, they lack support for large-scale traffic simulations. Recent work has emphasized providing analytical models for the DSRC and LTE C-V2X communication models to facilitate the simulation of large-scale traffic scenarios and applications. The third category includes research that evaluated applications while considering the communication system constraints. The limited communication bandwidth causes congestion in transmitting signals and data in the CV system, especially during peak demand periods when there are overwhelming data that require transmission. Therefore, the third area focuses on previous studies that accounted for communication system constraints when evaluating the impacts of CV applications.

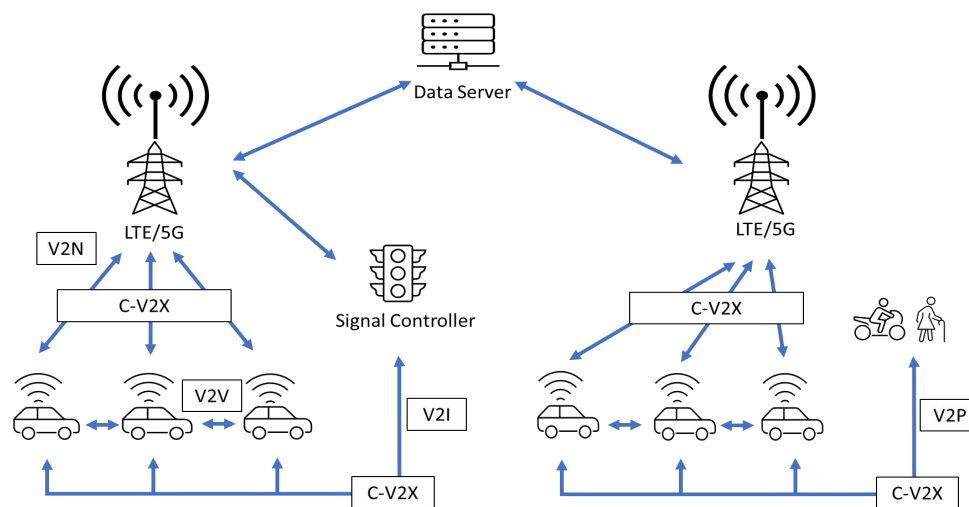

Figure 1. Graphical illustration of C-V2X.

Indeed, the deployment plan for 5G-C-V2X has begun and is expanding very quickly. However, the current 5G-C-V2X deployment is aiding advanced use cases and not replacing LTE-4G C-V2X, which is used for basic safety use cases [8–11]. Both technologies will coexist, and vehicles can communicate with each other using both technologies as illustrated in Figure 2. Consequently, we believe that, at least for the foreseeable future, LTE-4G C-V2X will continue.

Researchers have actively studied future communication technologies such as Next Generation (NextG), Beyond 5G (B5G), or 6G. These communication technologies leverage many advanced features, including massive access, terahertz (THz) frequency, ultra-high data rates, edge computing, artificial intelligence (AI), federated learning, and cloud computing. Such features provide a suitable environment for advanced applications like advanced mission-critical vehicular network applications, industrial Internet of Things, and advanced smart remote health services.

Zeb et al. [12] surveyed integrating physical and cyber worlds via cyber-physical systems (CPSs) and digital twin (DT) systems. The authors identified the roles of different technologies in CPSs and DT systems as well as their various requirements from the perspectives of communication and computing. They discussed recent examinations of NextG wireless technologies (5G and B5G) and how NextG satisfies the requirements of the industrial processes using the CPS and DT technologies.

Khan et al. [13] introduced an optimization framework for minimizing transmission power in V2X networks by using backscatter communications (BC) with a non-orthogonal multiple access (NOMA), which are two fundamental technologies in NextG wireless networks (B5G or 6G). The two components of NextG (BC and NOMA) improve energy and spectral efficiency and provide massive connectivity.

Leonardo et al. [14] discussed how the O-RAN Alliance's proposed disaggregated network architecture is critical to NextG networks. The authors interrogated different aspects of data-driven optimization (AI) approaches to network control. In addition, they mentioned that NextG network characteristics will be natively cloud-based, programmable, virtualized, and disaggregated. The AI will be embedded into the control layer by separating the control functions and the hardware fabric and introducing standardized software-defined control interfaces. Leonardo et al. demonstrated this via a large-scale wireless network emulator that involved closed-loop integration of real-time analytics and control through deep learning.

Jianhua et al. [15] explored the mutual dependency between 6G and CAVs. The 6G features like THz frequency, cell-free communication, AI, edge computing, federated learning, virtualized control function, and massive connectivity can be leveraged to satisfy mission-critical services for CAVs. CAVs can be used to facilitate both 6G system deployment and operations.

Xiang et al. [16] discussed vehicle communication channel measurement, modeling, and analysis in the B5G and 6G era. They showed how B5G and 6G features support advanced V2X applications like higher transmission rate (1 Tbps) by using ultra-massive multiple-input multiple-output (MIMO) and millimeter wave (mmWave) frequency. The authors provided a guideline to select and/or combine existing and emerging B5G and 6G vehicle communication channel models.

Security is a particularly important aspect of intelligent transportation system (ITS) applications. C-V2X communication protocol provides identity security by removing the transmitting vehicle's identifiable information during V2V/V2I communication. Data shared through V2V/V2I communication are basic safety messages (BSMs) that do not include any of the transmitting vehicle's sensitive information. Furthermore, in most ITS applications, a decision will be made based on the average consensus from various messages rather than just one message (in case of false information). Our concern in this paper is safety, environmental, and mobility ITS applications that use BSM information only and thus require basic security measures, which are implemented in the 4G LTE C-V2X communication protocol. Further studies on the security aspects are warranted, but beyond the scope of this paper.

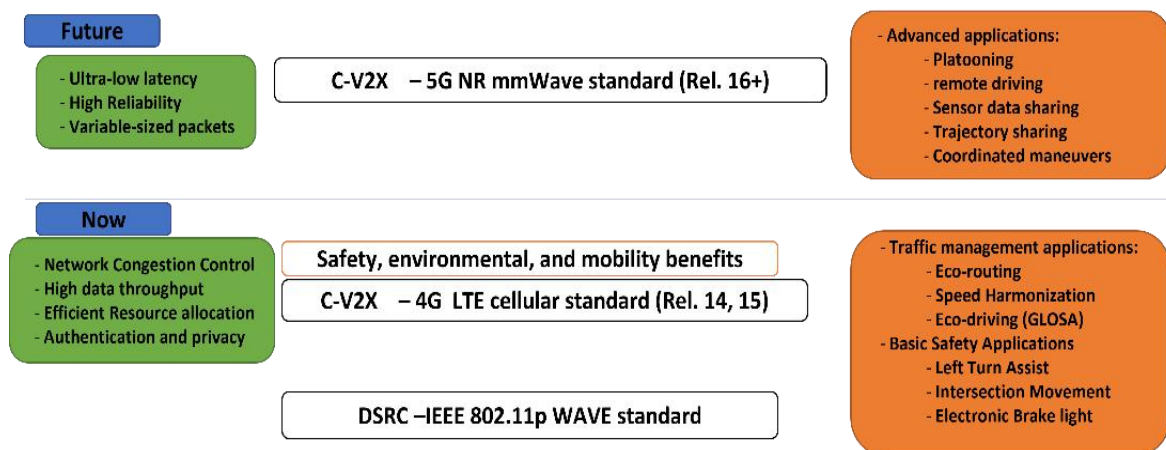

Figure 2. Categories of communication protocols used in CV applications.

2. Application Evaluations Ignoring Communication System Constraints

Most of the extant literature on CV applications does not consider the communication system constraints on system performance. Specifically, these studies assume that the data related to vehicle locations, vehicle

kinematics, infrastructure status, traffic controls, and travelers of all the modes in the transportation network can be transmitted to each agent in the system instantaneously with no loss or delay in data packets.

We found that most C-V2X studies tested CV applications in a specific environment. For example, some applications were only tested on uninterrupted freeway sections, while other studies tested their applications only at signalized and/or non-signalized intersections; also, some studies evaluated C-V2X applications for an entire network or at the city level.

In this study, we placed C-V2X literature into four categories: network-level applications, freeway applications, signal-free intersection applications, and signalized corridor applications, as described in the following sections. We utilized these categories to compare the benefits of similar C-V2X applications in each category.

2.1 Network Applications

This section summarizes the various efforts reported in the literature quantifying the network-wide impacts of CV applications. As summarized in Table 1, we found a limited number of studies focusing on network-wide impacts of CV applications. All studies entailed evaluating these applications in a virtual traffic simulation environment given that actual field implementations are cost prohibitive.

Ahn et al. [17] developed and evaluated an Eco-Cooperative Automated Control (Eco-CAC) system with the purpose of integrating vehicle control strategies with CAV applications. The authors tested their developed system on a large-scale network in downtown Los Angeles, CA. Testing involved a combination of hybrid electric vehicles (HEVs), battery electric vehicles (BEVs), and internal combustion engine vehicles (ICEVs) in a microscopic traffic simulation environment. The study also examined three different demand (congestion) levels: none, mild, and heavy. Included in the Eco-CAC system were an eco-router; an Eco-Cooperative Adaptive Cruise Control at Intersections (Eco-CACC-I) controller, also known as green light optimized speed advisory (GLOSA); a speed harmonization (SPD-HARM) controller; and an Eco-Cooperative Adaptive Cruise Control on Uninterrupted flow facilities (Eco-CACC-U) controller, also known as vehicle string control or platooning. According to study findings, the Eco-CAC system reduced fuel consumption by as much as 16.8%, CO₂ emissions by up to 16.8%, travel time by up to 21.7%, energy consumption by up to 36.9%, stopped delay by up to 68.7%, and total delay by up to 43.1%. Results also indicated different benefits generated according to vehicle type. For instance, in heavily congested conditions, the Eco-CAC system reduced fuel consumption, total delay, travel time, stopped delay, and CO₂ emissions for ICEVs. The benefits of the controllers mostly increased as the CAV MPR increased, although the controllers had a negative effect on ICEV fuel consumption, total delay, stopped delay, travel time, and CO₂ emissions for mild or no congestion. For BEVs, the Eco-CAC system improved energy consumption but negatively affected total delay, stopped delay, and travel time for all congestion levels. In addition, the authors tested the Eco-CAC system according to current and projected vehicle composition on the Los Angeles network, with findings indicating effective reductions in fuel and energy consumption, total delay, stopped delay, and travel time for both current and future compositions in heavily congested conditions. Conversely, the study noted different results for different vehicle compositions. Specifically, the authors observed the highest BEV energy consumption savings for the current vehicle composition (36.9%) at a 10% CAV MPR in mild congestion, whereas they observed the highest savings for the future vehicle composition (35.5%) at a 50% CAV MPR with no congestion. Results indicated the developed Eco-CAC system was effective in reducing fuel and energy consumption, total delay, stopped delay, travel time, and CO₂ emissions for BEVs, ICEVs, and HEVs for specific scenarios. Additionally, the Eco-CAC system's and controllers' effectiveness depends on traffic conditions, including congestion level, CAV MPR, network configuration, and vehicle composition [17].

Charoniti et al. [18] investigated various CV use cases in a study for the Netherlands Organization for Applied Science (TNO). The researchers reviewed available literature on the environmental impact of CV use cases and performed simulation studies using a microscopic emission calculation tool (EnViVer) to quantify the potential environmental impacts of CV applications. EnViVer was developed using the VISSIM traffic microsimulation software and VERSIT+, a vehicle emission simulation tool. The identified mechanisms that were taken into consideration include reduction of trips, reduction and departure time shift, mode shift, reduction of vehicle dynamics, and the powertrain operation. The results showed that an eco-driving technique that reduces vehicle stops is greatly beneficial, generating a CO₂ reduction in the range of 13–45%. An eco-driving technique that reduces deceleration and acceleration shows benefits as well (3–7% improvement). The study found that cooperative adaptive cruise control (CACC) reduces vehicle emissions by 6% compared to adaptive cruise control (ACC) [18].

Olia et al. [19] studied CV applications' potential impacts by using PARAMICS. The simulation tested was a network in Northern Toronto. The results of the simulation showed that CVs were able to navigate through multiple routing options and therefore could save up to 58% in travel time at an MPR of 50% on certain corridors. As for improving safety indicators, increasing the MPR of CVs can improve the safety index (the probability of incidents) by up to 45%. Researchers used the Comprehensive Modal Emission Model (CMEM) to estimate emission factors, identifying a reduction of 30% in CO₂ emissions [19].

Vahidi and Sciarretta [20] reviewed CAVs' energy-saving potential using optimal control theory and first principles of motion. The study found that anticipation of upcoming events improves with connectivity to other vehicles and infrastructure; events include curves, hills, slow traffic, traffic signal state, and movement of neighboring vehicles. The authors concluded that automation helps vehicles adjust their motion with greater precision to save energy, and cooperative driving has the potential to increase energy efficiency for a group of vehicles by enabling more coordinated movement. The study concluded that CAVs' energy-efficient movement could have a harmonizing impact in mixed traffic, thereby saving additional energy among neighboring vehicles [20].

Rahman et al. [21] used simulation to examine CVs and lower-level automation (CVLLA) and their impact on safety. Two features were tested as CVLLA: automated braking and lane keeping assistance. The authors estimated segment and intersection crash risks via surrogate safety assessment modeling techniques. Results showed that both CV and CVLLA technology significantly reduced conflict frequency. Higher MPRs of CVs generate higher benefits, with maximum improvement at 100% MPR. However, achieving reduced intersection crash risks requires at least 40% MPR, and 30% is needed for reduced segment crash risks [21].

Ahn et al. [22] developed a multi-objective routing algorithm (for both eco- and travel time-optimum routing) for ICEVs and BEVs in a CV environment and investigated the network-wide effects of the multi-objective Nash optimum (user equilibrium) traffic assignment on a large-scale network. Results showed BEVs have greater energy efficiency on low-speed arterial trips compared to highway trips, unlike ICEVs. The authors demonstrated that different eco-routing strategies are required for these vehicles' different energy consumption patterns. Findings indicated single objective eco-routing could lead to significant reductions in BEV energy consumption, but it also increased BEV average travel time significantly. As a result, the authors developed a multi-objective travel time- and eco-routing model to improve both travel time and energy measures. The simulation study demonstrated that multi-objective routing reduced BEV energy consumption by 13.5% in "not congested" conditions, 14.2% in "slightly congested" conditions, 12.9% in "moderately congested" conditions, and 10.7% in "highly congested" conditions; ICEV fuel consumption was reduced by 0.1% (not congested), 4.3% (slightly congested), 3.4% (moderately congested), and 10.6% (highly congested), respectively. Results also showed multi-objective user equilibrium routing reduced average vehicle travel time by as much as 10.1% from the standard user equilibrium traffic assignment for highly congested conditions, which produced a solution closer to the system optimum traffic assignment. The study concluded that multi-objective eco-routing can effectively reduce vehicle fuel/energy consumption with minimal effect on travel time for ICEVs and BEVs [22].

Abdelghaffar et al. [23] conducted a study to develop and test a dynamic freeway speed controller that was based on sliding mode theory. The sliding mode control's advantages include simple design, global stability, and robustness that can address the discontinuity of the fundamental diagram resulting from the capacity drop. The authors developed an SPD-HARM controller to identify bottlenecks and regulate CV speeds dynamically. They used a decentralized phase split/cycle length controller to optimize all traffic signals in the network. Results showed a 12% reduction in average travel time, a 21% reduction in total delay, and a 3.3% reduction in CO₂ emissions. In addition, the results showed that freeways benefit from the controller more than arterials [23].

In summary, we found that CV application benefits were highly dependent on application type, network settings, MPRs, and test algorithms. There were very few studies that focused on benefits at a network/system level. More studies concentrated either on freeways only or on signalized intersection corridors only. The following two sections illustrate these two categories.

2.2 Freeway Applications

Numerous studies investigated and quantified the impacts of CV enabled applications on freeway sections, as summarized in Table 2. Some of these studies concentrated on car-following and lane-changing behavior using a basic multi-lane freeway segment without any other complex roadway configurations. Some concentrated on studying the disturbance of merging or diverging traffic on a mainline freeway by analyzing freeway sections with on- and off-ramps. For example, in a pre-deployment project for Korean freeways, Jang et al. [24] analyzed crash risks and estimated safety benefits of the forward hazardous situation warning

information that a cooperative ITS (C-ITS) presented. A C-ITS is composed of onboard units, roadside units (RSUs), and a traffic management center. The authors adopted the crash potential index (CPI) to quantify the crash benefits of CVs and instrumented 700 CVs, including 400 buses, 264 trucks, and 36 sports utility vehicles, with data acquisition systems and V2X communication devices. The study found that C-ITS reduced the average speed by 10.2% and increased the time-to-collision (TTC) by 5.3%, which significantly improves the safety benefits of the proposed system. Findings also indicated the achievable CPI reduction was approximately 20.7% as a result of the warning information provided [24].

To study connected vehicular technologies' effectiveness and network communication efficiency in alerting motorists when they are approaching a hazardous zone (i.e., using CV technology to recommend a proper speed for travelers going through a low visibility area), Outay et al. [25] compared V2V and V2I communication performance in an extensive computer simulation experiment. The authors adapted the iTetris platform for various scenarios—a baseline scenario, a deactivated alert scenario, a V2V cooperative alert scenario, and a V2I alert scenario. The authors also explored, via simulations, whether Cooperative Hazard Awareness and Avoidance systems based on V2V and V2I communications have the potential to support eco-driving by reducing CO₂ emissions. The alerting system based on V2I communication yielded better message reception rates and safety efficiency. The results also showed that the Cooperative Hazard Awareness and Avoidance system can reduce CO₂ emissions using SPD-HARM [25].

Liu et al. [26] conducted analyses at a freeway merge bottleneck to study the effects of CACC on vehicle fuel efficiency in mixed traffic. Their results showed that CACC string operation reduced energy consumption compared to human drivers by up to 20%. At a 100% MPR, CACC-equipped vehicles consumed 50% less fuel than ACC vehicles without V2V communication and cooperation. Vehicle fuel efficiency was improved at lower CACC MPRs by implementing a dedicated CACC lane or wireless connectivity on manually driven vehicles. These strategies generated a 15% to 19% capacity increase at a CACC MPR of 40% without decreasing vehicle fuel efficiency. Such findings highlight how important it is to incorporate V2V cooperation into an automated speed control system and deploy CACC-specific operation strategies at lower CACC MPRs [26].

Li et al. [27] tested the effectiveness of integrating variable speed limit (VSL) and ACC in an I2V system by using simulation coding in MATLAB. The results showed that both the surrogate crash risk measures—time exposed TTC (TET) and time integrated TTC (TIT)—were reduced. ACC-only and VSL-only methods both had positive impacts: ACC-only reduced TET by 59.0% and TIT by 65.3%; VSL-only reduced TET by 53.0% and TIT by 58.6%. The I2V system achieved the greatest safety benefits by combining the advantages of ACC and VSL, reducing TET values by 71.5% and TIT values by 77.3% [27].

Rahman and Abdel-Aty [28] compared the implementation of managed-lane and all-lane CV platoons (for the same MPR) over a non-CV scenario to evaluate longitudinal safety of CV platoons. The authors proposed a high-level control algorithm of CVs in a managed-lane, forming platoons with three joining strategies: rear join, front join, and cut-in join. The study employed five surrogate safety measures as safety evaluation indicators: standard deviation of speed, TET, TIT, time exposed rear-end crash risk index, and sideswipe crash risk. Findings indicated safety in the studied expressway significantly improved with CVs. Managed lane control produced better improvements than all-lane control for the same MPR [28].

Jin et al. [29] used microsimulation in an evaluation of a CV application's environmental and mobility benefits, with the application involving a real-time optimal lane selection algorithm. On average, the application reduced travel time by up to 3.8% and fuel consumption by 2.2%. Furthermore, the reduction in criteria pollutant emissions (e.g., CO, HC, NO_x, and PM_{2.5}) ranged from 1% to 19%, depending on the different roadway segment congestion levels [29].

Guériau et al. [30] conducted a study to model complex interactions between cooperative vehicles and potentially among vehicles and infrastructure by integrating multi-agent cooperative traffic modeling into the MovSim, a traffic simulator. The authors discussed the potential for C-ITS in traffic management and the methodological issues that come with the expansion of such systems. Their operational goal was to develop a decision-making tool validated in simulation conditions and tailored to cooperative strategies. The model involved three layers and incorporated different dynamics to account for information reliability and limit traffic disturbances, thereby homogenizing the traffic flow. Results showed that, at a 40% to 50% MPR, the connected environment had benefits in terms of homogenization and was able to avoid congestion for the merging traffic from on-ramps and a scenario where a lane was closed [30].

Monteil et al. [31] constructed a multi-agent framework for modeling a cooperative auto-adaptive system, with the assumption that modeling and technology uncertainties affect traffic physics and communications. The authors employed a three-layer framework (physical, communication, and trust) to homogenize traffic flow. By modeling trust as a function of distances, along with a communication layer and a physical layer, the authors

conducted simulations using two lanes of freeway traffic with an entrance flow distribution from US-101 sample data. Results showed that the operation could decrease the speed variance and thus the likeliness that traffic would take on local congestion. The cooperation can also minimize the influence of aggressive drivers (who work against a global gain in acceleration when they change lanes). Raising MPR lowers the effect of aggressive lane-changing behaviors because it increases stability, homogenizes traffic, and reduces the multiplying effect of any disturbances [31].

Liu et al. [32] studied the impact of CACC string operations on fuel economy and vehicle speed on a 13-mile section of the SR-99 corridor near Sacramento, CA. The authors used simulation to evaluate the corridor's performance under different CACC MPR scenarios and traffic demand levels. The authors also analyzed the CACC string operation when a CACC managed lane and a vehicle awareness device (VAD) were implemented. According to the results, average vehicle speeds increased by 70% when the CACC MPR increased from 0% to 100%. The study achieved the highest average fuel economy, expressed in miles per gallon (mpg), under the 50% CACC scenario with 27 mpg, 10% higher than the baseline scenario. Increases to vehicle fuel efficiency were only minor, however, when the CACC MPR was 50% or higher. At a 100% CACC MPR, the corridor could have 30% more traffic enter the network with no reduction to average speeds. In addition, findings indicated that implementing the VAD increased speed by 8% when the CACC MPR was 20% or 40%, with a minor decrease in the fuel economy. The CACC managed lane, when implemented alone, decreased the corridor performance [32].

Ard et al. [33] conducted a study to demonstrate an anticipative car-following algorithm's effectiveness in reducing gasoline engine and electric CAVs' energy use with no negative impacts on safety and traffic flow. The authors implemented a vehicle-in-the-loop testing environment that involved driving experimental CAVs on a track and interacting in real-time with the surrounding virtual traffic. Energy savings were also explored in microsimulations. Model predictive control (MPC) managed high-level velocity planning, and its performance benefited from a preceding CAV communicating intentions or from estimating a preceding human-driven vehicle's probable motion. The authors achieved acceleration tracking at the low level with a combination of classical feedback control and data-driven nonlinear feedforward control of pedals. They also implemented controllers in a robot operating system and measured energy via calibrated OBD-II readings. Results of the study indicated energy savings of 30% [33].

Weng et al. [34] proposed a model-free approach to incorporate elements of varied vehicle types and combine the goals of fuel economy and mobility platooning. The authors formulated a utility function using the Nelder-Mead approach, which depends on instantaneous communication of speed and fuel consumption between vehicles in the platoon with mixed vehicle types. The simulation and experimental results showed that this method was effective in increasing the objective function, with less fuel consumption and higher mobility. However, due to the data-driven nature, convergence required some time [34].

Kamal et al. [35] constructed an MPC framework to drive a vehicle on multi-lane roads efficiently by enhancing the vehicle's capability in lane change and speed adjustment. MPC predicts future behavior using present state information through the explicit use of a process model. Results showed that the MPC generated optimal vehicle acceleration and optimal timing to move to the next lane if it anticipated long-term performance gain by predicting surrounding traffic [35].

Wang et al. [36] proposed Altruistic Cooperative Driving (ACD), a strategy whereby vehicles causing congestion yield the right of way to other vehicles by slowing down or changing lanes. By defining the vehicle driving conditions into maximum, deadlock, and free-run, the strategy changes the deadlock situation into a free-run or maximum situation to improve overall efficiency. A simulator was generated using Java for a section of multi-lane road. The results showed that the ACD strategy achieved higher speed efficiency, with up to 15% improvement, and it can resolve deadlock conditions in a timely manner by performing cooperative driving [36].

Ghiasi et al. [37] designed a CAV-based trajectory-smoothing method to control CAVs upstream of a bottleneck to improve fuel-efficiency, harmonize traffic, and reduce environmental effects. Four steps were adopted: information update, shooting heuristic, trajectory prediction, and damping control. Results showed that the proposed methodology smoothed CAV movements and harmonized the following human-driven vehicles. Improvements were achieved in throughput, fuel consumption, surrogate safety measures, and speed variations [37].

Table 1. V2X-Enabled Network Applications

References	Leading Author, Institute	CV Application	Road type	Comm. type	Topic area	Estimated Benefits	Simulation/ Field Test	Modeling Environment
[17]	Ahn, K – VTTI	Various – Eco-routing, SPD-HARM, Eco-approach and departure, Platooning	Network	N/A	Mobility, Environment	Reduced fuel consumption by up to 16.8%, CO ₂ emissions by up to 16.8%, travel time by up to 21.7%, BEV energy consumption by up to 36.9%, stopped delay by up to 68.7%, and total delay by up to 43.1%.	Simulation	INTEGRATION, VT-CPFM, VT-CPEM
[18]	Charoniti, E. – TNO	Various – CACC, Eco-driving, Intelligent intersection	Arterial and Freeway	N/A	Environment	CO ₂ reduction in the range of 13–45%.	Simulation	EnVIer (VISSIM and VERSIT+)
[19]	Olia, A – McMaster University	Routing and safety	Network	N/A	Mobility, Safety, Environment	Reduced travel time by 37%, reduced emissions by 30% and improved safety indicators by 45%.	Simulation	Paramics, CMEM
[20]	Vahidi, A – Clemson	Review paper – Various	Network	N/A	Environment	This paper summarizes the benefits of coordinated and smoother CAV movement in terms of car following, lane changing, and intersection control on energy savings and environment impacts. The authors concluded that from previous literatures, the savings on energy can range from 3% to 20% on varied facilities.	N/A	N/A
[21]	Rahman, MS – University of Central Florida	Automated braking and lane keeping assistance	Arterial	N/A	Safety	Travel time saving between 59% to 84%.	Simulation	VISSIM
[22]	Ahn, K – VTTI	Eco-Routing	Network	N/A	Energy	The multi-objective routing reduced ICEV fuel consumption up to 10.6% and BEV energy consumption up to 14.2%.	Simulation	INTEGRATION, VT-CPFM, VT-CPEM
[23]	Abdelghaffar, H – VTTI	SPD-HARM	Network	N/A	Mobility, Environment	20.67% reduction in total delay, 12.17% reduction in travel time, 2.6% fuel consumption saving, CO ₂ emission savings of 3.3%	Simulation	INTEGRATION, VT-CPFM

Table2. V2X-Enabled Freeway Applications

References	Author, Leading institute	CV Application	Roadway Type	Comm. Type	Topic Area	Estimated Benefits	Simulation/Field Test	Modeling Environment
[24]	Jang, J. – Hanyang University	Forward hazardous situation warning system	Freeway	Dedicated Short Range Communications (DSRC) (1 Hz)	Safety	Reduction in the CPI was approximately 20.7 %; TTC increased by 5.3%	Field test	
[25]	Outay, F. – Zayed University, UAE	Hazardous zone detection and alert system	Freeway	DSRC	Safety, Environment	TTC improved slightly; CO ₂ improved by 5%	Simulation	iTetris platform (SUMO)
[26]	Liu, H. – UC Berkeley	CACC	Freeway	N/A	Mobility, Environment	Maximum 20% reduction in energy consumption; Up to 49% of capacity increase	Simulation	NGSIM (VT-CPFM+MOVES)
[27]	Li, Y. – Southeast University	Variable Speed Limit (VSL) and Adaptive Cruise Control (ACC)	Freeway	N/A	Safety	TET and TIT were reduced by 53% and 58.6% for VSL; 59% and 65.3% for ACC; 71.5% and 77.3% for combined VSL and ACC	Simulation	MATLAB
[28]	Rahman, M – University of Central Florida	Platooning	Freeway	DSRC of 300 m (1000 feet)	Safety	All five surrogate measures of safety (standard deviation of speed, TET, TIT, time exposed rear-end crash risk index, sideswipe crash risk) improved. Managed-lane CV outperformed all-lane CV platooning.	Simulation	VISSIM
[29]	Jin, Q. – University of California Riverside	Optimal Lane Selection (OLS)	Freeway	N/A	Safety, Environment	Travel time reduced 3.8%; fuel consumption reduced 2.2%; emissions reduced from 1% to 19%, according to the level of congestion.	Simulation	SUMO
[30]	Gueriau M. – Université de Lyon	Advanced Driver Assistance System (ADAS)	Freeway	N/A	Safety, Mobility	Speed decreased with an homogenization of speeds and headways	Simulation	A multi-agent framework embedded with MovSim
[31]	Monteil J. – Université de Lyon	Cooperative Car Following	Freeway	N/A	Mobility	With the cooperative traffic, aggressive lane-changing behavior is reduced, and the stability and homogenization of traffic is achieved.	Simulation	OVRV and MOBIL
[32]	Liu, H. – UC Berkeley	Platooning	Freeway	N/A	Mobility, Environment	Average mpg of 27 was achieved when MPR is 50%; mobility increased 30% with MPR of 10%.	Simulation	MOVES and VT-CPFM models

[33]	Ard, T. – Clemson University	CV Car following control with MPC	Freeway	V2Sim	Mobility, Environment	Improvement of 30% in energy economy; increased travel time and headway.	Simulation	Automated driving virtual simulation with a physical vehicle (EGO)
[34]	Weng, Y. – U of Michigan	Eco-CACC	Freeway	N/A	Mobility, Environment	Utility improvement over initial speed is 40% in mobility and 2.2% in fuel economy; utility improvement over desired speed is 18.4% in fuel economy but at the cost of 7.5% mobility.	Simulation	military trucks
[35]	Kamal, M.A.S. – Gunma University	Model Predictive Control (MPC)	Freeway	N/A	Mobility	6.79% increased velocity and 7.22% fuel economy.	Simulation	MATLAB
[36]	Wang, N. – Fujitsu Laboratories	Altruistic Cooperative Driving (ACD)	Freeway	N/A	Mobility	ACD achieves higher speed efficiency (up to 15%).	Simulation	Traffic simulator implemented in Java
[37]	Ghiasi, A. – University of South Florida	SPD-Harm	Freeway	N/A	Mobility, Environment	Varied benefits from different sensor settings. The savings on throughput, speed STD, fuel consumption, and surrogate safety measures can be up to 1.7%,6.5%,4%, and 17%.	Simulation	VT-Micro
[38]	Liu, H. – UC Berkeley	CACC	Freeway	N/A	Mobility	Managed lane and vehicle awareness device are helpful at low and medium MPR, leading to a capacity improvement ranging from 8% to 23%.	Simulation	NGSIM (VT-CPFM+MOVES)
[39]	Bichiou, Y. – VTTI	Platooning	Freeway		Mobility, Environment	Travel time, delay, fuel consumption all dropped for connected automated vehicles (CAVs) and non-connected vehicles, with reduction up to 5%, 9.4%, and 8.17%.	Simulation	INTEGRATION

Liu et al. [38] conducted a study to model the impacts of CACC on mixed traffic flow on multi-lane freeway facilities. The authors proposed a modeling framework that generates high-volume traffic flow via a new vehicle dispatching model. The framework also ensures realistic CACC vehicle behaviors. By incorporating automated speed control algorithms and new lane changing rules, the proposed modeling framework could further reproduce traffic flow dynamics that are influenced by CACC operation strategies. Case studies on four-lane freeway segments with on- and off-ramps were illustrated, and results indicated that their proposed modeling framework could improve system mobility for different MPRs. Specifically, at a 60% or lower MPR, managed lane and vehicle awareness devices were helpful and led to a capacity improvement ranging from 8% to 23%. At a 100% MPR, the freeway capacity was 90% higher than the base case [38].

Bichiou et al. [39] proposed an input minimal platooning controller that incorporates various dynamic and kinematic constraints related to acceleration, velocity, and collision avoidance. The authors tested the controller using a calibrated real network—freeways in downtown Los Angeles—in a simulation environment utilizing the INTEGRATION microscopic simulation software. Findings showed that a significant reduction in system-wide travel time, delays, and fuel consumption was achievable. It was also observed that, although the controller only controlled vehicles in the platoon, all the vehicles in the network benefited from the controller [39].

In summary, CV-enabled applications in uninterrupted traffic flow typically regulate car-following and lane-changing behavior to minimize fuel consumption, maximize throughput, and improve surrogate crash measures, such as the standard deviation of speed, TTC, etc. The results varied case by case depending on the different applications, congestion levels, and/or MPRs of CVs. In most cases, the percentage of CVs needed to be above a certain level to achieve meaningful results. Most previous studies used simulation tools to evaluate application effectiveness, and field tests were rare due to the scarcity of equipped facilities as well as safety concerns.

2.3 Signal-free Intersection Applications

Dresner and Stone [40] introduced the concept of signal-head-free intersection control, and their approach considered a first-in, first-out intersection control mechanism. Mirheli et al. [41] also designed a signal-head-free intersection control logic that used a dynamic programming model. The authors determined near-optimal actions over time to prevent conflicts by employing a stochastic look-ahead technique on a Monte Carlo tree search algorithm. In doing so, the model they developed maximized the intersection throughput. The simulation results indicated significant reduction in travel time at intersections for different demand patterns. Depending on various demand patterns, the improvement ranged between 59% and 84% compared to intersections controlled by fixed-time and fully actuated traffic signals [41].

In a similar way, Zohdy et al. developed the intersection CACC system to regulate traffic flow proceeding through signal-head-free intersections [42–44]. Zohdy and Rakha [45] extended this work to optimize traffic flow proceeding through a roundabout. Elhenawy et al. [46] then investigated the use of game theory to optimize vehicle movements through the intersection. Later, Bichiou and Rakha [47] developed a signal-head-free offline controller and extended it to real-time vehicle trajectory optimization considering dynamic constraints to enhance the mobility of intersections. Results of further study by Bichiou and Rakha [48] showed that their proposed algorithm outperformed other intersection control strategies by not only producing lower delay but also decreasing vehicle fuel consumption and CO₂ emissions. In summary, CACC and i-CACC are efficient in decreasing delays and fuel consumption compared to conventional signal controls, abandoning the concepts of intersection control by optimizing the scheduling and movement of vehicles traversing an intersection. Table 3 lists the studies for signal-free intersections. The existing studies were mainly conducted in a simulation environment.

2.4. Signalized Roadway Applications

Numerous studies have attempted to quantify the benefits of V2X enabled applications along signalized roadways. These V2X applications were designed to improve energy consumption, mobility, and the environment around a single or multiple signalized intersections. These CV control applications are represented as GLOSA and Eco-CACC-I control systems. Several studies tested V2X enabled applications along arterials with one or more signalized intersections, where there are traffic controls that force vehicles to decelerate, stop, and/or accelerate at the onset, during, or at the conclusion of a red indication. By using the data transmitted from other vehicles and infrastructures, the V2X enabled applications can guide vehicles through intersections with minimum delays and emissions and without colliding into other vehicles by sharing signal phasing and timing (SPaT) data. Table 4 summarizes these studies.

Kamalanathsharma and Rakha [49–52] developed GLOSA systems around signalized intersections. In their studies, the authors introduced a dynamic programming approach for deriving fuel-optimum vehicle trajectory. Yang et al. extended this work by predicting the queue at the intersection approach [53] and considering multiple signalized intersections in deriving the optimum solution [54]. By varying demand level, MPRs, phase splits, offsets, and the distances among the consecutive traffic signals, they concluded that a fuel consumption saving of 13.8% can be achieved given a 100% MPR. Their efforts also produced greater fuel savings by combining higher MPRs with shorter phase lengths. Traffic signal offset, demand levels, and traffic signal spacing all affect the results [54]. Later, Almannaa et al. [55] tested the controller in a controlled field environment. The authors tested three scenarios: normal driving, driving with a speed advisory, and automated Eco-CACC. The field experiment tested four red indication offset values randomly delivered to drivers along an uphill and downhill route, totaling 1,563 trips by 32 different participants. Findings showed that the proposed Eco-CACC system can reduce fuel consumption significantly; savings in fuel consumption of 31% and travel time of 9% were achieved. The results also demonstrated that automatic control yields more significant benefits than a human control scenario [55].

An early GLOSA system was implemented and tested in the field by Bradaï et al. [56]. This system prompts the driver to adapt their speeds such that the vehicle can safely proceed through upcoming traffic signals during a green indication. The system enables reducing stop times and unnecessary accelerations in urban traffic situations, thereby saving fuel and reducing CO₂ emissions. Findings revealed a significant reduction in CO₂ emissions. However, the authors also stated that the results were obtained under specially designed circumstances where the trip length was only 1,500 meters and the experiment environment involved a straight line with no other vehicles [56].

An eco-approach application was designed to provide drivers with recommendations that promote “green” driving while passing through, approaching, and departing intersections in a study conducted by Xia et al. [57]. The authors conducted simulation experimentation as well as field operational testing to demonstrate the eco-approach application and quantify any potential CO₂ and fuel savings. The results showed a communication platform based on a 4G/LTE C-V2X network link and a cloud-based server infrastructure was sufficient and effective for this type of application. In the simulation experiment and the field operational testing, results indicated 14% fuel and CO₂ savings could be achieved, on average [57].

To reduce energy consumption, Wang et al. [58] developed a cluster-wise cooperative eco-approach and departure (Coop-EAD) application for CAVs and compared its performance to existing Ego-EAD applications. Rather than focusing on CAVs traveling through signalized intersections one at a time, this study strategically coordinated CAVs’ maneuvers to create clusters using different operating modes: intra-cluster sequence optimization, initial vehicle clustering, and cluster formation control. The study then applied the novel Coop-EAD algorithm to the cluster leader, with CAVs in the cluster following the cluster leader to conduct EAD maneuvers. In the preliminary simulation study for a given scenario, results indicated that the proposed Coop-EAD application produced an 11% reduction in energy consumption, up to an 18% reduction in pollutant emissions, and a 50% increase in traffic throughput, respectively, compared to an Ego-EAD (speed and location) application [58].

Moser et al. [59] proposed a CACC approach using stochastic linear model predictive control strategies. Both V2I and V2V communication were assumed present. With this approach, the objective was to minimize fuel consumption in a vehicle-following scenario. The authors estimated the probability distribution of the upcoming velocity of the preceding vehicle based on current measurements and upcoming traffic signal timings using a conditional Gaussian model. Compared to the predecessor, the evaluation of the controllers showed a significant reduction in vehicle fuel consumption while also increasing safety and driving comfortably [59].

Bento et al. [60] designed a novel intersection traffic management system for CAVs. In this study, the developed intelligent traffic management (ITM) techniques were proved to be successful in reducing the delays and emissions without colliding. The data needed for the ITM system is supported by V2X communication where the vehicle position and speed are exchanged among vehicles and infrastructure. In addition to the savings in CO₂ emissions and delays, the authors also found that improvement is more significant when traffic is heavier [60].

To minimize fuel consumption, Wan et al. [61] proposed a speed advisory system (SAS) for pre-timed traffic signals. They showed the minimal fuel driving strategy changes between periods of maximum acceleration, engine shut down, and occasionally constant speed. Instead of using this bang-singular-bang control, they employed a sub-optimal solution without significantly sacrificing the drivability but with significant improvement in fuel economy. The SAS-equipped vehicles both improved their own fuel economy

and benefited other conventional vehicles. A higher MPR generated more fuel savings. The cost in traffic flow and travel time was minimal [61].

Lee and Park [62] performed a simulation-based case study implemented on a hypothetical four-way single-lane approach intersection under varying congestion conditions. Their findings revealed that, compared to conventional actuated intersection control, the Cooperative Vehicle Intersection Control (CVIC) algorithm significantly improved intersection performance with a 99% reduction in stopped delay and 33% reduction in total travel time. The CVIC algorithm also showed significant improvements in air quality and energy savings with a 44% reduction of CO₂ and 44% fuel consumption savings [62].

Looking at congested traffic and traffic signals common in urban road conditions, HomChaudhuri et al. [63] developed a fuel-efficient control strategy for a group of connected HEVs. With a focus on minimizing the average tractive energy consumption and reducing red light idling, the authors employed a higher-level controller to develop an optimal velocity profile. Via an adaptive equivalent consumption minimization strategy (ECMS), the lower-level controller then tracks the velocity profile from the higher-level controller by optimally splitting power between the vehicle engine and the battery. The results of the simulation showed that with the proposed method, no vehicle had to stop for red lights. ECMS can perfectly track the velocity the higher-level controller supplies, and it can maintain battery charge within 1.5% of the initial battery state [63].

Liu et al. [64] designed a cooperative signal control algorithm utilizing data collected by traditional fixed traffic sensors and CACC data sets. The control strategy proved to be effective with mixed traffic as well as 100% CACC traffic. The average vehicle speed and mpg increased by more than 10%; speed increased by 13% when the CACC MPR was 100%, while the speed increased by 36% and mpg improved by more than 34% when the CACC MPR was 40%. Even with a 0% CACC, the proposed method can generate benefits with speed improvements of 12.5% and mpg improvements of 12.2% [64].

Lebre et al. [65] developed a GLOSA system and showed that GLOSA could lower vehicle emissions, waiting time, and travel times. One feature of this study is that it involved real scenario testing. The authors tested the traffic signal with communication devices that transmitted identity, timestamp, location, and phase information. The data were sent to the V2X equipment, which comprised an IEEE802.11p compliant WiFi router and an antenna mounted to the traffic light, through an Ethernet connection. In the case when there was only one vehicle, both simulation and the in-field test achieved similar savings in CO₂ emissions (11% and 13%). When there was more than one vehicle included (only in simulation), 5% savings in CO₂ emissions and 30% in waiting time were observed when the MPR was around 50%. Authors conducted the simulations with two other networks, finding that the savings in time and CO₂ emissions were also significant: a reduction of 10.5% in CO₂ emissions and an 80% decrease in waiting time were observed for the grid network with an MPR of 100%; the travel time reduction was about 2.05% with 50% vehicle MPR and 50% infrastructure MPR for the Valeo shuttle transit route. When the CAV MPR increased to 50% and 60% for infrastructure, the savings increased quickly to 16% [65].

Chen and Rakha [66] developed a connected eco-driving controller for BEVs that assists BEVs trying to negotiate signalized intersections by minimizing their energy consumption. This controller features multiple realistic constraints, including vehicle acceleration and deceleration behavior, BEV energy consumption behavior, and the intercorrelation of speed, location, and signal timing in a CV environment. The results showed that the authors' controller can reduce stop-and-go behavior effectively while simultaneously generating 9.3% energy consumption savings and 3.9% savings in delays [66]. In another study, the same authors developed an HEV Eco-CACC system to calculate real-time energy-optimized trajectories for HEVs. Within the system, two models are developed: one HEV energy model to determine the instantaneous fuel consumption and one vehicle dynamics model to determine the relationship between acceleration, speed, and tractive/resistance forces. On an arterial with three signalized intersections, results revealed that the proposed system reduced energy consumption by 7.4%, delays by 5.8%, and vehicle stops by 23% [67].

Using two methods—game-theoretic decentralized and centralized perimeter control—Elouni et al. [68] designed an adaptive traffic signal control system and compared the performance of both methods. Findings indicated that the Nash Bargaining (NB) traffic signal controller can prevent congestion from building and improve the entire network's performance. The NB controller outperforms both non-gating and gating controllers with significant reductions in vehicle travel time, emissions, fuel consumption, and delays. Specifically, the decentralized NB controller, with or without gating, led to significant reductions of 21% to 41% in total delay, 40% to 55% in CO₂ emission levels, and 12% to 20% in fuel consumption [68].

Table 3. V2X-Enabled Arterial Applications at Non-Signalized Intersections

References	Author, Leading institute	CV Application	Road Type	Comm. type	Topic Area	Estimated Benefits	Simulation/Field Test	Modeling Environment
[40]	Dresner, K. – University of Texas, Austin		Arterial	N/A	Mobility	Average trip time for the proposed reservation system is always at the optimum level, comparing to stop sign, traffic signal-controlled intersections, as well as the overpass	Simulation	
[41]	Mirheli, A. – State University of New York at Stony Brook		Arterial	N/A	Mobility	A signal-head-free intersection control logic was developed and will completely avert incidents and significantly reduce travel time ranging between 59% and 84%.	Simulation	VISSIM
[42]	Zohdy, I. – VTTI	CACC, i-CACC	Arterial	N/A	Mobility and Environment	Demonstrated savings in delay and fuel consumption in the range of 91% and 82%, respectively, relative to conventional signal control.	Simulation	INTEGRATION
[43]	Zohdy, I. – VTTI	CACC	Arterial	N/A	Mobility	The proposed system reduces the total delay relative to a traditional stop control by an average of 35 seconds, corresponding to an approximately 70% reduction in total delay.	Simulation	
[44]	Zohdy, I. – VTTI	CACC, i-CACC	Arterial	N/A	Mobility and Environment	Four types of intersection control methods were compared and the results show the proposed i-CACC system significantly reduces the average intersection delay and fuel consumption level by 90% and 45%, respectively.	Simulation	INTEGRATION
[45]	Zohdy, I. – VTTI	CACC	Arterial	N/A	Mobility and Environment	The proposed system can reduce delay and fuel consumption up to 80% and 40%, respectively.	Simulation	
[46]	Elhenawy, M. – VTTI	CACC	Arterial	N/A	Mobility	The proposed algorithm demonstrated reduction in travel time and delay in the range of 49% to 89% compared to an all-way stop sign control.	Simulation	INTEGRATION
[47]	Bichou, Y. – VTTI	N/A	Arterial	N/A	Mobility and Environment	The model developed in this study optimized the movements of AVs subjected to dynamical constraints and static constraints. The results demonstrate that an 80% reduction in delay is achievable compared to the best of the following intersection control strategies, on average: roundabout, stop sign, and traffic signal-controlled intersection. A 42.5% and 40% reduction in vehicular fuel consumption and CO ₂ emissions, respectively.	Simulation	INTEGRATION

References	Author, Leading institute	CV Application	Road Type	Comm. type	Topic Area	Estimated Benefits	Simulation/Field Test	Modeling Environment
[48]	Bichiou, Y. – VTTI	N/A	Arterial	N/A	Mobility and Environment	The control system proposed is proved to be effective in achieving 55% reduction in delay compared to roundabout, four-way stop sign, or traffic signal-controlled intersection. It also yielded a 43% reduction in fuel consumption and CO ₂ emissions.	Simulation	INTEGRATION
						respectively, were achieved as well.		

Table 4. V2X-Enabled Arterial Applications at Signalized Intersections

References	Author, Leading institute	CV Application	Road Type	Comm. type	Topic Area	Estimated Benefits	Simulation/Field Test	Modeling Environment
[49]	Kamalanathsharma, R. – VTTI	Eco-CACC	Arterial	N/A	Environment	The model proposed by the authors can save fuel consumption by up to 30% in proximity of signalized intersections.	Simulation	INTEGRATION
[50]	Kamalanathsharma, R. – VTTI	Eco-CACC	Arterial	N/A	Environment	The proposed trajectory optimization was calibrated and tested on 30 top-sold vehicles using a moving horizon dynamic programming approach, and results showed saving in fuel consumption ranging from 5% to 30%.	Simulation	
[51]	Kamalanathsharma, R. – VTTI	Eco-CACC	Arterial	N/A	Environment	The model proposed by the authors can save fuel consumption in proximity of signalized intersections by up to 30%.	Simulation	INTEGRATION
[52]	Kamalanathsharma, R. – VTTI	N/A	Arterial	N/A	Environment	The proposed variable throttle model provides significant fuel savings. Additional savings of 37% was observed when the Dijkstra minimum path algorithm was applied and savings of 14% was achieved when using an A-start minimum path finding algorithm.		
[53]	Yang, H. – VTTI	Eco-CACC	Arterial	N/A	Environment	The results showed a fuel savings of up to 40% can be achieved with a 10% MPR. Multiple lane approach requires a higher MPR compared to a single lane approach to generate significant results.	Simulation	INTEGRATION
[54]	Yang, H. – VTTI	Eco-CACC	Arterial	N/A	Environment	An eco-driving system that calculates a fuel-optimized trajectory was proposed. Using SPaT data communicated from downstream, the eco-driving system can produce a reduction of 13.8% in fuel consumption with an MPR of 100%.	Simulation	INTEGRATION

References	Author, Leading institute	CV Application	Road Type	Comm. type	Topic Area	Estimated Benefits	Simulation/Field Test	Modeling Environment
[55]	Almanaa, M. – VTTI	Eco-CACC	Arterial	N/A	Mobility, Environment	Travel time was reduced by 9% (downhill 8.1%, uphill 9.9%) and fuel consumption by 31% (downhill saving 38.4% uphill saving 22.6%).	Simulation and Field Test	INTEGRATION
[56]	Bradai, B. – Valeo, France	GLOSA	Arterial	DSRC – V2X	Environment	Cumulative CO ₂ emissions for a 1500 m distance travel (max speed 50km/h or 70km/h) decreased by 13%	Field test	Detailed algorithm is not included
[57]	Xia, H. – UC Riverside	Eco-approach and departure	Arterial	CV2X-LTE	Environment	An average of 14% fuel and CO ₂ savings can be achieved both for simulation and the field test. Travel time decreased by 0.96%.	Field test, Simulation	Params
[58]	Wang, Z. – UC Riverside	Coop-EAD	Arterial	N/A	Environment	Throughput improved by 50%, energy consumption decreased by 11%, and emissions were reduced up to 20%.	Simulation	MATLAB/Simulink and MOVES
[59]	Moser, D. - University of Linz, Austria	CACC	Arterial	N/A	Environment	A CACC control approach was proposed and the fuel consumption in a vehicle-following scenario was minimized.	Simulation	
[60]	Bento, L. – Instituto Politécnico de Leiria	Intelligent Traffic Management techniques	Arterial	N/A	Safety, Environment	The Intelligent Traffic Management techniques reduced the CO ₂ emissions significantly, and the benefit increased with the demands	Simulation	INTEGRATION
[61]	Wan, N. – Clemson University	Speed Advisory System	Arterial	N/A	Environment and Mobility	A sub-optimal solution was proposed to avoid bang-bang control. Much fewer stops and smoother trajectories were obtained with fewer less consumption	Simulation	Params
[62]	Lee, J. – University of Virginia	Cooperative Vehicle Intersection Control (CVIC)	Arterial	N/A	Mobility, Environment	99% and 33% stop delay and total travel time reductions (comparing to actuated intersection control); 44% reductions of CO ₂ , and 44% savings of fuel consumption.	Simulation	VISSIM
[63]	HomChaudhuri, B. - Clemson University		Arterial	N/A	Environment	Decreased delays significantly by eliminating stops for red lights. The fuel efficiency improved about 50% and CO ₂ emission decreased about 40%	Simulation	HEVs
[64]	Liu, H. – UC Berkeley	CACC - Arterial	Arterial	N/A	Mobility, Environment	Fuel efficiency increased more than 10% and speed increased by 13% when MPR was 100% (36% increase in speed and 34% MPG if MPR was 40%). 67% of capacity increase was observed for major approach and 49% was observed for the minor approach.	Simulation	NGSIM/PATH
[65]	Lebre, M.A –	GLOSA	Arterial	DSRC	Mobility,	10% reduction in CO ₂ when MPR was 100%; 5% reduction in CO ₂ and 30% reduction in waiting time was observed (with 40% vehicle	Field test,	SUMP

References	Author, Leading institute	CV Application	Road Type	Comm. type	Topic Area	Estimated Benefits	Simulation/ Field Test	Modeling Environment
	VALEO, France				Environment	MPR and 50% infrastructure MPR).	Simulation	
[66]	Chen, H. – VTTI	Eco-CACC	Arterial	N/A	Mobility, Environment	9.3% savings in energy consumption and 3.9% in vehicle delays were observed.	Simulation	INTEGRATION
[67]	Chen, H. – VTTI	Eco-CACC	Arterial	N/A	Mobility, Environment	Reduced energy consumption by 7.4%, delays by 5.8%, and vehicle stops by 23%.	Simulation	INTEGRATION
[68]	Elouni, M. – VTTI	Decentralized Nash Bargaining Traffic Controller (DNB)	Arterial	N/A	Mobility, Environment	The reductions, with or without gating, are (on average): travel time between 21% to 41%, in total delay between 40% to 55%, and in emission levels (CO ₂) and fuel consumption between 12% to 20%.	Simulation	INTEGRATION
[69]	Maille, D. – Mercedes-Benz Research & Development	CICAS-V	Arterial	DSRC	Safety	The system can reliably send out warning messages 100% of the time and therefore prevent crashes from happening.	Field test	

Maile [69] tested a cooperative intersection collision avoidance system using vehicles from five OEMs: Daimler, Ford, GM, Honda, and Toyota, among which the GM vehicle contained the full prototype. The intersection at 5th Avenue and El Camino Real in Atherton, CA, was used for the testing. Results showed that the system can send out warnings with almost 100% reliability and therefore prevent crashes from happening [69].

In summary, C-V2X signalized roadway applications typically involve speed advisory systems where vehicles are advised on how to traverse a traffic signal-controlled intersection to avoid unnecessary deceleration, acceleration, and/or stops. Most applications either recommend speeds to drivers or adjust vehicle speeds upstream of traffic signals using SPaT data received through V2I communication to minimize their energy consumption. The existing studies were mainly conducted in a simulation environment. Most of them examined conventional ICEVs, though some tested other vehicle types, such as BEVs or trucks and buses. Most studies presented promising results in terms of environmental, mobility, and safety improvements. It should be noted that while the applications were developed for the same purpose, namely, to enhance vehicle movements through signalized intersections, each application has its own attributes. For example, most applications use different optimization techniques to reduce the computational time and maximize the benefits of their applications. In addition, each application uses different fuel/energy consumption models and different objective functions and/or constraints.

3. Modeling Mutual Dependencies of Transportation and Communication Systems

This section contains brief descriptions of current work on modeling transportation and communication system interdependencies as related to the evaluation of V2X applications, summarized in Table 5.

A well-known framework in this category is Veins, which uses the TraCI interface to integrate a traffic simulator, SUMO, and a communication simulator, OMNET++. TraCI is a messaging standard that applies the Transmission Control Protocol (TCP) connections to share messages across the two simulators. TraCI's advantages include allowing bidirectional coupling of the two simulators. A key shortcoming of Veins, however, is its inability to model large-scale networks. By default, Veins does not support C-V2X mode 4, but OpenCV2X [70] has extended Veins to support C-V2X modeling by implementing the C-V2X standard in SimuLTE. SimuLTE is built on top of OMNET++ to support LTE communication [71].

Eckermann et al. [72] developed another integrated simulator that involved integrating the SUMO traffic and NS-3 communication simulators. To support C-V2X release 14, the authors extended NS-3; they did not discuss how they achieved the integration between NS-3 and SUMO, but we assume that, similarly to Veins, they used the TraCI interface, as it is the external interface for SUMO developed by the SUMO authors.

In two studies, Elbery et al. [73,74] developed an integrated simulator, VNetIntSim, by combining the OPNet communication simulator with the INTEGRATION traffic simulator. The authors used the integrated framework to show the effect of mobility parameters (traffic density and stream speed) on communication performance via various applications such as the File Transfer Protocol using TCP and Voice over Internet Protocol based on the User Datagram Protocol [73,74].

To address the scalability problem, Hoque et al. [75] conducted a study in support of simulating large-scale road networks with hundreds of thousands of vehicles; this involved parallelizing one or both simulators to accelerate execution time. Incorporating hardware-in-the-loop simulation with the integration of SUMO and OMNET++, the authors developed an Integrated Distributed Connected Vehicle Simulator (IDCVS). The study included a partitioning heuristic algorithm that separates a complex traffic network into two sets: one for SUMO and one for OMNET++. The authors then used the tool for modeling DSRC for connected vehicles considering various market penetration levels [75].

The third category of methods includes the Vehicular Network Simulator (VNS), which integrates DIVERT 2.0, a traffic simulator, and NS-3, a communication system simulator. VNS was developed before the C-V2X LTE standard release and therefore supports the 802.11p communication standard. This simulator is different from those discussed previously because of how NS-3 and DIVERT are integrated. Rather than have the two executing programs communicate with each other, they were put into one executable environment because both simulators were developed in the same programming language (C++). The two simulators still communicate using TCP connections through the network integration module even as they share an execution environment. VNS runs the traffic simulator first followed by the communication simulator at each simulation time step. The communication simulator has node entities mapped to vehicle entities in the traffic simulator, and

every node entity has access to its corresponding vehicle entity. The adaptation of the NS-3 network simulator is another difference in VNS from previous examples. Fernandes et al. [76] adapted the implementation of NS-3 to support large-scale simulations using the concept of nearest neighbors and the locality of vehicle position updates via QuadTrees to accelerate the performance of the NS-3 communication simulator. The integrated simulator is still constrained by the computational speed of NS-3 [76].

Elbery and Rakha [77,78] developed a network simulator that simultaneously models the traffic and communication systems. Unlike previous work, the communication system abstraction is not a network simulator, but instead is an analytical model, which allows for large-scale modeling of CV applications. To estimate packet drop probability and delay via a Markov chain and queuing model, the authors developed an analytical communication model for the DSRC Media Access Control layer protocol. They implemented the analytical model in the INTEGRATION microscopic traffic simulator and employed a dynamic eco-routing application to test the integrated framework [77,78].

Continuing the work of Elbery and Rakha, Farag et al. [79] developed an integrated C-V2X and traffic simulation framework to simultaneously model the traffic and communication systems and their bidirectional coupling in a large-scale road network. The authors again used the INTEGRATION traffic simulator and an analytical model to implement the communication features of C-V2X and coupled them together in one execution environment. They scaled up the running time by leveraging a spatial index to accelerate the computation time of the communication model and tested it on the downtown Los Angeles network, modeling approximately 145,000 vehicles [79]. In Table 6, we summarize the various parameters associated with the different simulator studies. This includes simulation times, road networks, number of vehicles simulated, and execution time for the different CV application simulators.

In summary, developing a fully integrated traffic and communication simulator is essential for modeling CV applications. Most studies integrate the two systems using dedicated simulators in the respective fields, which models low-level details of both systems but lacks the capability of large-scale simulations. Recent work uses analytical modeling techniques to substitute one of the dedicated simulators for the benefits of scaling to large-scale simulations without significantly sacrificing the accuracy of the modeling tool.

4. Application Evaluations Considering the Communication System Constraints

This section describes how the tools developed in the previous section are useful in performance assessment of various CV applications while also revealing the transportation and communication systems' mutual interdependencies.

Schiegg et al. [80] studied the environmental awareness problem of vehicles on the road, which they called incomplete vehicle perception due to the onboard sensors' limited range. They proposed extending vehicle perception by sharing the vehicle's information, collected by its own sensors, with other vehicles on the road via C-V2X communication technology. The service of sharing information within vehicles on the road is called collective perception. The authors proposed and applied an analytical model to evaluate the service's performance using the C-V2X Mode 4 standard. The authors found that the collective perception service enhanced the information when using C-V2X to share sensors' information. They also found that although C-V2X was useful, more enhancement was needed regarding the latency requirements of vehicle safety applications [80].

Segata et al. [81] studied the C-V2X communication standard's performance in the context of platooning applications. The authors investigated the scheduling algorithm for Mode 4's effect on the platoon formation using several controllers. Findings suggested that although C-V2X performed very well regarding packet delivery ratio, it did not perform well in terms of packet loss bursts. The authors showed that the packet loss bursts can hinder C-V2X usefulness in safety applications and claimed that the packet loss bursts are due to the scheduling algorithm and the half-duplex nature of the C-V2X channel (vehicles cannot receive and transmit at the same time) [81].

Rajab and Miucic [82] investigated the performance of the C-V2X communication standard with two safety applications as use cases: Emergency Vehicle Alert and High Beam Assist. The authors modeled the C-V2X communication standard using empirical data from the Crash Avoidance Metrics Partners performance assessment project to create several packet error ratio (PER) curves for different conditions (ideal, medium, and severe). They smoothed the PER curves using splines applied to the empirical data [82].

A truck platoon application was tested in [79] using C-V2X communication. The authors found that the best scenario is to use C-V2X Mode 3 in areas covered by LTE-infrastructure and that C-V2X Mode 4 achieves the best benefits from the platoon (i.e., smaller inter-truck gaps) in areas not covered. The authors, however, noted that one critical C-V2X Mode 4 configuration is the re-selection counter, which must be tuned carefully to achieve good performance [83].

Malinverno et al. [84] developed an open-source framework for testing V2X applications. They evaluated two applications—emergency vehicle (V2V) and area speed advisory (V2I/V2N)—using DSRC and C-V2X communication technologies. Findings showed that the two applications were valuable and did help the emergency vehicle to maintain high speeds while crossing intersections (in the V2V case) and decreased the number of collisions in the area of the speed advisory applications (in the V2I/V2N case) [84].

Mouawad et al. [85] tested and evaluated a cooperative collision avoidance V2I application at urban intersections. The vehicles shared their lidar sensor measurements (local occupancy maps) with RSUs. The RSUs fused all the messages into a global occupancy map and sent it back to all vehicles in range. The authors found that the configuration for the best performance was a message size of 1,685 bytes for global occupancy maps, which led to the lowest obstacle mis-detection rate and a packet generation rate of 10 Hz, whereas the number of vehicles was less than 70 and 5 Hz otherwise [85].

Malinverno et al. [86] introduced a C-V2I-based system for collision avoidance and evaluated its collision detection algorithm's effectiveness using Cooperative Awareness Messages sent by vehicles and pedestrians using C-V2I. The configuration of the communication protocol was not clear, but the authors mentioned that they used SimuLTE-veins for simulating the C-V2I. The authors assumed an MPR of 100% and tested the location of the application server in two settings: the cloud and at the RSU. The results of their algorithm were not affected by the location of the application server [86].

Magalhaes et al. [87] introduced a video-assisted overtaking maneuver application using image processing and video streaming over C-V2X. The C-V2X enhanced the performance of the application by having low packet loss and high video quality; however, it did affect the latency. The authors used a C-V2X onboard unit with a Cooperative Awareness Messages frequency of 10 Hz, HARQ enabled, and transmission power of 20 dBm with line-of-sight assumption [87].

A study conducted by 5GAA analyzed the capability of IEEE 802.11p (DSRC or ITS-G5) and 3GPP LTE-V2X PC5 (LTE side-link) in reducing the number of fatalities and serious injuries. The model used the number of crashes as a baseline and the fraction of signal delivery reliability, effectiveness of receiving alert/warning message, and other ratios to estimate the number of crashes that could be avoided. The results showed that LTE-V2X would avoid a greater number of crashes when compared to 802.11p because of the superior performance of LTE-V2X combined with the market-led conditions that favor the deployment of LTE-V2X [88].

In their study, Rebbeck et al. [89] concluded that C-V2X enhances traffic efficiency and road safety. The base and equitable 5.9 GHz user scenario appeared to be the most beneficial way to deploy C-V2X considering the cost of upgrading the roadside infrastructure. Additional benefits can be achieved if LTE PC5 communication is integrated in smartphones. The study also concluded that the cost of upgrading the in-vehicle C-ITS system would be significant [89].

Beyrouty et al. [90] evaluated seven bundles of C-ITS services that are mature and expected to deploy in the short or medium term, including safety-based V2V services, V2I services that deliver the most benefit on motorways, V2I services mostly applicable in urban areas, services intended to provide information regarding parking, services intended to provide traffic and smart routing information, and V2X vulnerable road user protection services. The authors also assessed policy options considering six key themes: privacy, security, interoperability, compliance assessment, continuity, and enabling conditions. They estimated the savings in avoiding crashes, fuel consumption savings, and emission reductions for different policy options [90].

Using the INTEGRATION simulation tool, Elbery and Rakha [91,92] evaluated the mutual influence of an eco-routing transportation application and the V2I communication system using the 802.11p protocol. They tested the eco-routing application performance using different measures of effectiveness for different CV MPRs and congestion levels. The results of their study showed that reasonable fuel savings were achieved at a low-to-medium MPR. However, at high MPRs and high vehicular traffic congestion levels, the eco-routing application performance degraded and caused higher fuel consumption and even gridlock in the road network. This was because the high packet drop rate caused the eco-routing application to produce sub-optimal routes [91,92]. Alternatively, ignoring the communication system constraints produced benefits that increased as the CV MPR increased. This study clearly demonstrated the need to model the communication system as part of the evaluation of CV applications and demonstrated that erroneous conclusions could be derived without such an integrated modeling framework.

Table 5. Comparison of Integrated Traffic and Communication Simulators

References	Author - Institute	Integrated Simulator	Simulation Scale	Network Simulator	Comm. Standard	Vehicle Positions	Simulator Coupling	Spatial Analysis	Modeling Environment
[70]	Sommer, C. – University of Erlangen	VEINS	Small scale	OMNET++	IEEE 802.11b	NA	Fixed interval	No	SUMO
[71]	McCarthy, B – University College Cork Ireland	OpenC-V2X	Small scale	OMNET++	C-V2X	NA	Fixed interval	No	SUMO
[72]	Eckermann, F – TU Dortmund University	Open Source C-V2X	Medium Scale	NS-3	C-V2X	NA	Fixed interval	No	SUMO
[73]	Elbery, A – VTTI	VNetIntSim	Medium scale	OPNET	IEEE 82.11g	NA	Fixed interval	No	INTEGRATION
[74]	Elbery, A – VTTI	INTEGRATION	Large scale	Analytical model	DSRC (IEEE 802.11p)	NA	Fixed interval	No	INTEGRATION
[75]	Hoque, M.A. – East Tennessee State University	IDCVS	Large scale	OMNET++	DSRC (IEEE 802.11p)	NA	Fixed interval	Yes	SUMO
[76]	Fernandes, R. – University of Porto, Portugal	VNS	Large scale	NS-3	DSRC (802.11b)	Quad Tree	Fixed interval	No	DIVERT
[77,78]	Farag, M – VTTI	INTEGRATION	Large scale	Analytical model	Direct C-V2X	Grid cell and update index	Dynamic interval	Yes	INTEGRATION

Table 6. Road Network Architecture and Simulation Time

References	Author – Institute	Road Network	Simulation Time	Number of Vehicles	Execution Time
[70]	Sommer, C. – University of Erlangen	A 2700 m six-lane highway section, lane width of 4 m, vehicular speeds of 140 km/h (70 km/h). The inter-vehicle distance of $2.5 \text{ s} \times$ maximum speed.	Not reported	200 (380) vehicles in the simulation at its most dense stage	Not reported
[71]	McCarthy, B – University College Cork Ireland	Single-lane Manhattan Grid with intersections spaced 1 km apart. Grid sizes 5×5 roads and 16×16 roads.	Not reported	30 and 1000 vehicles	Not reported
[72]	Eckermann, F – TU Dortmund University	A $100 \text{ m} \times 100 \text{ m}$ intersection, and an urban Manhattan grid scenario as used by 3GPP ($750 \text{ m} \times 1299 \text{ m}$).	30 s	250 vehicles	Not reported
[73]	Elbery, A – VTTI	An intersection and four zones. Each zone serves as a vehicle origin and destination location. Each road link is 2 km long.	Not reported	3000 vehicles with 180 concurrent vehicles	Not reported
[74]	Elbery, A – VTTI	Downtown LA. Area 133 km^2 . 1625 nodes, 3561 links, and 459 traffic signals (42 RSUs).	8.3 h	563,626 vehicles with a maximum of 30,000 concurrent vehicles	8.3 h
[76]	Fernandes, R. – University of Porto, Portugal	Road network of city of Porto.	40 min	130,000 vehicles with a maximum of 15,000 concurrent vehicles	7 h
[77]	Farag, M – VTTI	Downtown LA. Area 133 km^2 . A total of 1624 nodes, 3556 links, and 457 traffic signals.	1.8 h	145,000 vehicles with a maximum of 30,000 concurrent vehicles	1.5 h

In summary, V2X-enabled intelligent transportation applications like collective perception, platooning, emergency vehicle alert, area speed advisory, collision avoidance, and video-assisted overtaking maneuvers have been tested in the literature. Despite the promising benefits of V2X technology, there is still more room for enhancement, specifically from the latency perspective.

5. Open Research Directions

This paper reviewed numerous research efforts that attempted to quantify the effects of various CV applications on the transportation system's mobility, safety, and the environment. As such, we have derived the following conclusions based on the literature review:

1. CV applications are highly efficient in improving the transportation system's mobility and safety and minimizing vehicle emissions and fuel consumption levels. Assuming perfect wireless communication among the different components of the CV environment, the mobility, safety, and environmental impacts typically increase as the CV MPR increases.
2. CVs' MPR is a critical factor affecting the performance of CV applications. A minimum MPR was recommended in many studies to reach a significant level of savings in travel time, delays, and emissions. Depending on the types and features of the different applications, the minimum MPR varies from 10% to 40%.
3. The benefits of CV applications generally increase with the increase of MPR if communication constraints are not explicitly accounted for. The benefits, however, do not follow a linear relationship with the MPR. Some applications start to show effects once a minimum number of CVs are in the traffic flow, but the benefits flatten out after the MPR reaches a certain level. Some applications do not generate benefits until a certain MPR level is attained; however, benefits increase accordingly with the increasing percentage of CVs in the traffic flow.
4. Most of the previous research efforts treated the communication among various parts of the system as latency- and/or error-free, assuming the C-V2X data are accepted and applied by all users without an error. This assumption should be modified in future research. Due to the delays in signal transmission, bandwidth, and varied levels of acceptance and cooperation of travelers in the system, the benefits will be lower in real-world situations. The benefits in the real world need to be estimated accordingly to account for limitations in the communication system and ensure accuracy.
5. A unique study of an eco-routing application showed that a minimum MPR of about 10% was needed to achieve benefits, with the benefits peaking at a CV MPR of 30–40%. Higher MPRs overloaded the 802.11p communication system, and at an MPR of 75%, the application produced gridlock because of the loss and latency in the packet transmission. This finding is unique because it demonstrates the importance of including the communication system constraints in the modeling of CV applications.
6. Most previous research efforts were based on microscopic simulations. Very few studies tested CV technologies in the field given the high cost of such testing. Even in those cases with field testing, the testbed typically was a closed environment involving a small sample of CVs (no more than 10), thus not overloading the communication system.
7. The benefits of CV applications vary based on the application type, study design, vehicle type, test location or network type, roadway condition, and utilized energy/emission model. The differences might also be caused by different modeling algorithms, modeling assumptions, or model parameter settings.

In conclusion, to fully interrogate a C-V2X system's impacts, we need to integrate the knowledge of two major fields involving C-V2X technology and the operation of the transportation system.

6. Recommendations for Further Research

The impacts of CV applications in previous studies have been based on assumptions in one field or another where the efficiency is perfect and/or with zero obstacles. This is not true in the real-world. A realistic direction for further research into C-V2X is to incorporate the likely uncertainty in both systems, such as the effects of failures in the process of communication, the propagation of traffic flows where a bottleneck may move backwards or congestion may spill back and sideways to other locations in a road network, delays in

responsiveness to traffic congestion and traffic controls, mixed traffic with varied percentages of connected and regular vehicles, and any other dynamic characteristics of the transportation and communication systems.

Based on the findings of previous research, we recommend the following research directions:

1. Further research is needed to develop C-V2X application protocols that can define minimum modeling requirements. This could include variables like vehicle type, test location or network configuration, roadway congestion level, and market penetration levels.
2. Modeling tools that capture the interdependency of the transportation and communication systems are critical to the assessment of CV applications. Further research is needed to develop scalable modeling tools that provide a good abstraction of the communication and transportation systems.
3. Validation of simulation-dominant studies using high fidelity modeling tools or real-world empirical data is needed.
4. Further work is needed to quantify the impact of varied MPRs and C-V2X applications using these integrated modeling tools to identify the most effective parameters and identify bottlenecks in the communication system.
5. The large-scale system-wide impact of C-V2X applications up to the country level should be investigated to support a transportation policy decision making process.

Conflict of Interest

All authors declare that they have no conflicts of interest.

Appendix

Abbreviations

5G	the 5th generation mobile network
ACC	Adaptive Cruise Control
BEV	Battery Electric Vehicle
CACC	Cooperative Adaptive Cruise Control
C-ITS	Cooperative Intelligent Transport System
Coop-EAD	Cooperative Eco-Approach and Departure
CPI	Crash Potential Index
CV	Connected Vehicle
C-V2X	Cellular Vehicle-to-Everything
CVIC	Cooperative Vehicle Intersection Control
CVLLA	CVs and lower-level automation
DSRC	Dedicated Short-Range Communication
ECMS	Adaptive Equivalent Consumption Minimization Strategy
Eco-CAC	Eco-Cooperative Automated Control
Eco-CACC	Eco-Cooperative Adaptive Cruise Control
EPA	Environmental Protection Agency
GLOSA	Green Light Optimal Speed Advisory
HEV	Hybrid Electric Vehicle
ICEV	Internal Combustion Engine Vehicle
IDCVS	Integrated Distributed Connected Vehicle Simulator
ITM	Intelligent Traffic Management
MPR	Market Penetration Rate
NB	Nash Bargaining
PER	Packet Error Ratio
RSU	Roadside Unit

SAS	Speed Advisory System
SPD-HARM	Speed Harmonization
TCP	Transmission Control Protocol
TET	Time Exposed Time to Collision
TIT	Time Integrated Time to Collision
TNO	Netherlands Organization for Applied Science
TTC	Time-to-Collision
V2C	Vehicle-to-Cloud Communication
V2D	Vehicle-to-Device Communication
V2G	Vehicle-to-Grid Communication
V2N	Vehicle-to-Network Communication
V2P	Vehicle-to-Pedestrian Communication
V2V	Vehicle-to-Infrastructure Communication
V2X	Vehicle-to-Everything Communication
VMT	Vehicle Miles Traveled
VNS	Vehicular Network Simulator
VSL	Variable Speed Limit

References

- [1] STATISTA. Global No. 1 Data Platform. 2019. Available online: <https://www.statista.com> (accessed on 1 October 2022).
- [2] Gardner, G. Americans Lost Nearly 100 Hours to Traffic in 2019, With Boston Ranking as Most Congested U.S. City in Latest INRIX Survey. 2020. Available online: <https://www.forbes.com/sites/greggardner/2020/03/09/americans-lost-nearly-100-hours-to-traffic-in-2019-says-inrix/?sh=541e6b57d5c8> (accessed on 1 October 2022).
- [3] Beltz, B. 100+ Car Accident Statistics. 2021. Available online: <https://safer-america.com/car-accident-statistics/> (accessed on 1 October 2022).
- [4] INRIX. INRIX 2021 Global Traffic Scorecard. 2021. Available online: <https://inrix.com/scorecard/> (accessed on 1 October 2022).
- [5] Inventory of U.S. Greenhouse Gas Emissions and Sinks. United States Environmental Protection Agency (EPA). 2021. Available online: <https://www.epa.gov/ghgemissions/inventory-us-greenhouse-gas-emissions-and-sinks> (accessed on 1 October 2022).
- [6] Sources of Greenhouse Gas Emissions. United States Environmental Protection Agency. Available online: <https://www.epa.gov/ghgemissions/sources-greenhouse-gas-emissions> (accessed on 1 October 2022).
- [7] 7 types of vehicle connectivity. 2021. Available online: <https://blog.rgbsi.com/7-types-of-vehicle-connectivity> (accessed on 1 October 2022).
- [8] Naik, G.; Choudhury, B.; Park, J.-M. IEEE 802.11bd & 5G NR V2X: Evolution of Radio Access Technologies for V2X Communications. *IEEE Access* **2019**, *7*, 70169–70184, <https://doi.org/10.1109/access.2019.2919489>.
- [9] Bazzi, A.; Cecchini, G.; Menarini, M.; Masini, B.M.; Zanella, A. Survey and Perspectives of Vehicular Wi-Fi versus Sidelink Cellular-V2X in the 5G Era. *Futur. Internet* **2019**, *11*, 122, <https://doi.org/10.3390/fi11060122>.
- [10] Garcia, M.H.C.; Molina-Galan, A.; Boban, M.; Gozalvez, J.; Coll-Perales, B.; Şahin, T.; Kousaridas, A. A Tutorial on 5G NR V2X Communications. *IEEE Commun. Surv. Tutor.* **2021**, *23*, 1972–2026, <https://doi.org/10.1109/COMST.2021.3057017>.
- [11] 5G Americans, Vehicular Connectivity: C-V2X & 5G. 2021. Available online: <https://www.5gamericas.org/vehicular-connectivity-c-v2x-and-5g/> (accessed on 1 October 2022).
- [12] Zeb, S.; Mahmood, A.; Hassan, S.A.; Piran, J.; Gidlund, M.; Guizani, M. Industrial digital twins at the nexus of NextG wireless networks and computational intelligence: A survey. *J. Netw. Comput. Appl.* **2022**, *200*, 103309, <https://doi.org/10.1016/j.jnca.2021.103309>.
- [13] Khan, W.U.; Jamshed, M.A.; Mahmood, A.; Lagunas, E.; Chatzinotas, S.; Ottersten, B. Backscatter-Aided NOMA V2X Communication under Channel Estimation Errors. In proceedings of 2022 IEEE 95th

- Vehicular Technology Conference: (VTC2022-Spring), Helsinki, Finland, 19–22 June 2022, <https://doi.org/10.1109/vtc2022-spring54318.2022.9860382>.
- [14] Bonati, L.; D'Oro, S.; Polese, M.; Basagni, S.; Melodia, T. Intelligence and Learning in O-RAN for Data-Driven NextG Cellular Networks. *IEEE Commun. Mag.* **2021**, *59*, 21–27, <https://doi.org/10.1109/mcom.101.2001120>.
- [15] He, J.; Yang, K.; Chen, H.-H. 6G Cellular Networks and Connected Autonomous Vehicles. *IEEE Netw.* **2020**, *35*, 255–261, <https://doi.org/10.1109/mnet.011.2000541>.
- [16] Cheng, X.; Huang, Z.; Chen, S. Vehicular communication channel measurement, modelling, and application for beyond 5G and 6G. *IET Commun.* **2020**, *14*, 3303–3311, <https://doi.org/10.1049/iet-com.2020.0531>.
- [17] Ahn, K.; Du, J.; Farag, M.; Rakha, H.A. Evaluating an eco-cooperative automated control system (Eco-CAC). *Transp. Res. Rec.* **2022**, <https://doi.org/10.1177/03611981221113315>.
- [18] Environmental Benefits of C-V2X. 2020. Available online: <https://5gaa.org/environmental-benefits-of-c-v2x/> (accessed on 1 October 2022).
- [19] Olia, A.; Abdelgawad, H.; Abdulhai, B.; Razavi, S.N. Assessing the Potential Impacts of Connected Vehicles: Mobility, Environmental, and Safety Perspectives. *J. Intell. Transp. Syst.* **2015**, *20*, 229–243, <https://doi.org/10.1080/15472450.2015.1062728>.
- [20] Vahidi, A.; Sciarretta, A. Energy saving potentials of connected and automated vehicles. *Transp. Res. Part C: Emerg. Technol.* **2018**, *95*, 822–843, <https://doi.org/10.1016/j.trc.2018.09.001>.
- [21] Rahman, M.S.; Abdel-Aty, M.; Lee, J.; Rahman, M.H. Safety benefits of arterials' crash risk under connected and automated vehicles. *Transp. Res. Part C Emerg. Technol.* **2019**, *100*, 354–371, <https://doi.org/10.1016/j.trc.2019.01.029>.
- [22] Ahn, K.; Bichiou, Y.; Farag, M.; Rakha, H.A. Multi-objective Eco-Routing Model Development and Evaluation for Battery Electric Vehicles. *Transp. Res. Rec. J. Transp. Res. Board* **2021**, *2675*, 867–879, <https://doi.org/10.1177/03611981211031529>.
- [23] Abdelghaffar, H.M.; Elouni, M.; Bichiou, Y.; Rakha, H.A. Development of a Connected Vehicle Dynamic Freeway Variable Speed Controller. *IEEE Access* **2020**, *8*, 99219–99226, <https://doi.org/10.1109/access.2020.2995552>.
- [24] Jang, J.; Ko, J.; Park, J.; Oh, C.; Kim, S. Identification of safety benefits by inter-vehicle crash risk analysis using connected vehicle systems data on Korean freeways. *Accid. Anal. Prev.* **2020**, *144*, 105675, <https://doi.org/10.1016/j.aap.2020.105675>.
- [25] Outay, F.; Kamoun, F.; Kaisser, F.; Alterri, D.; Yasar, A. V2V and V2I Communications for Traffic Safety and CO2 Emission Reduction: A Performance Evaluation. *Procedia Comput. Sci.* **2019**, *151*, 353–360, <https://doi.org/10.1016/j.procs.2019.04.049>.
- [26] Liu, H.; Shladover, S.E.; Lu, X.-Y.; Kan, X. Freeway vehicle fuel efficiency improvement via cooperative adaptive cruise control. *J. Intell. Transp. Syst.* **2020**, *25*, 574–586, <https://doi.org/10.1080/15472450.2020.1720673>.
- [27] Li, Y.; Wang, H.; Wang, W.; Liu, S.; Xiang, Y. Reducing the risk of rear-end collisions with infrastructure-to-vehicle (I2V) integration of variable speed limit control and adaptive cruise control system. *Traffic Inj. Prev.* **2016**, *17*, 597–603, <https://doi.org/10.1080/15389588.2015.1121384>.
- [28] Rahman, M.S.; Abdel-Aty, M. Longitudinal safety evaluation of connected vehicles' platooning on expressways. *Accid. Anal. Prev.* **2018**, *117*, 381–391, <https://doi.org/10.1016/j.aap.2017.12.012>.
- [29] Jin, Q.; Wu, G.; Boriboonsomsin, K.; Barth, M. Improving traffic operations using real-time optimal lane selection with connected vehicle technology. In proceedings of 2014 IEEE Intelligent Vehicles Symposium Proceedings, Dearborn, MI, USA, 8–11 June 2014, <https://doi.org/10.1109/ivs.2014.6856515>.
- [30] Guériau, M.; Billot, R.; El Faouzi, N.-E.; Monteil, J.; Armetta, F.; Hassas, S. How to assess the benefits of connected vehicles? A simulation framework for the design of cooperative traffic management strategies. *Transp. Res. Part C: Emerg. Technol.* **2016**, *67*, 266–279, <https://doi.org/10.1016/j.trc.2016.01.020>.
- [31] Monteil, J.; Billot, R.; Sau, J.; Armetta, F.; Hassas, S.; Faouzi, N.E.E. Cooperative Highway Traffic: Multiagent Modeling and Robustness Assessment of Local Perturbations. *Transp. Res. Rec. J. Transp. Res. Board* **2013**, *2391*, 1–10, <https://doi.org/10.3141/2391-01>.
- [32] Liu, H.; Lu, X.-Y.; Shladover, S.E. Mobility and Energy Consumption Impacts of Cooperative Adaptive Cruise Control Vehicle Strings on Freeway Corridors. *Transp. Res. Rec. J. Transp. Res. Board* **2020**, *2674*, 111–123, <https://doi.org/10.1177/0361198120926997>.

- [33] Ard, T.; Guo, L.; Dollar, R.A.; Fayazi, A.; Goulet, N.; Jia, Y.; Ayalew, B.; Vahidi, A. Energy and flow effects of optimal automated driving in mixed traffic: Vehicle-in-the-loop experimental results. *Transp. Res. Part C: Emerg. Technol.* **2021**, *130*, 103168, <https://doi.org/10.1016/j.trc.2021.103168>.
- [34] Weng, Y.; Salehi, R.; Ge, X.; Rizzo, D.; Castanier, M.P.; Heim, S.; Ersal, T. Model-free speed management for a heterogeneous platoon of connected ground vehicles. *J. Intell. Transp. Syst.* **2020**, *26*, 183–197, <https://doi.org/10.1080/15472450.2020.1797506>.
- [35] Kamal, M.A.S.; Taguchi, S.; Yoshimura, T. Efficient vehicle driving on multi-lane roads using model predictive control under a connected vehicle environment. In proceedings of the 2015 IEEE Intelligent Vehicles Symposium (IV), Seoul, Korea, 28 June–1 July 2015, <https://doi.org/10.1109/IVS.2015.7225772>.
- [36] Wang, N.; Wang, X.; Palacharla, P.; Ikeuchi, T. Cooperative autonomous driving for traffic congestion avoidance through vehicle-to-vehicle communications. In proceedings of 2017 IEEE Vehicular Networking Conference (VNC), Turin, Italy, 27–29 November 2017, <https://doi.org/10.1109/vnc.2017.8275620>.
- [37] Ghiasi, A.; Li, X.; Ma, J. A mixed traffic speed harmonization model with connected autonomous vehicles. *Transp. Res. Part C: Emerg. Technol.* **2019**, *104*, 210–233, <https://doi.org/10.1016/j.trc.2019.05.005>.
- [38] Liu, H.; Kan, X.; Shladover, S.E.; Lu, X.-Y.; Ferlis, R.E. Modeling impacts of Cooperative Adaptive Cruise Control on mixed traffic flow in multi-lane freeway facilities. *Transp. Res. Part C: Emerg. Technol.* **2018**, *95*, 261–279, <https://doi.org/10.1016/j.trc.2018.07.027>.
- [39] Bichiou, Y.; Rakha, H.; Abdelghaffar, H.M. A cooperative platooning controller for connected vehicles. In proceedings of 7th International Conference on Vehicle Technology and Intelligent Transport System, Online Streaming, 28–30 April 2021.
- [40] Dresner, K.; Stone, P. Multiagent traffic management: an improved intersection control mechanism. In proceedings of The Fourth International Joint Conference on Autonomous Agents and Multiagent Systems, Utrecht, The Netherlands, 25–29 July 2005, <https://doi.org/10.1145/1082473.1082545>.
- [41] Mirheli, A.; Hajibabai, L.; Hajbabaie, A. Development of a signal-head-free intersection control logic in a fully connected and autonomous vehicle environment. *Transp. Res. Part C: Emerg. Technol.* **2018**, *92*, 412–425, <https://doi.org/10.1016/j.trc.2018.04.026>.
- [42] Zohdy, I.H.; Rakha, H. Game theory algorithm for intersection-based cooperative adaptive cruise control (CACC) systems. In proceedings of 15th International IEEE Conference on Intelligent Transportation Systems, Anchorage, AK, USA, 16–19 September 2012, <https://doi.org/10.1109/itsc.2012.6338644>.
- [43] Zohdy, I.H.; Kamalanathsharma, R.K.; Rakha, H. Intersection management for autonomous vehicles using iCACC. In proceedings of 15th international IEEE conference on intelligent transportation systems, Anchorage, AK, USA, 16–19 September 2012, <https://doi.org/10.1109/itsc.2012.6338827>.
- [44] Zohdy, I.H.; Rakha, H.A. Intersection Management via Vehicle Connectivity: The Intersection Cooperative Adaptive Cruise Control System Concept. *J. Intell. Transp. Syst.* **2014**, *20*, 17–32, <https://doi.org/10.1080/15472450.2014.889918>.
- [45] Zohdy, I.H.; Rakha, H.A. Enhancing Roundabout Operations via Vehicle Connectivity. *Transp. Res. Rec. J. Transp. Res. Board* **2013**, *2381*, 91–100, <https://doi.org/10.3141/2381-11>.
- [46] Elhenawy, M.; Elbery, A.A.; Hassan, A.A.; Rakha, H.A. An Intersection Game-Theory-Based Traffic Control Algorithm in a Connected Vehicle Environment. In proceedings of 2015 IEEE 18th international conference on intelligent transportation systems, Gran Canaria, Spain, 15–18 September 2015, <https://doi.org/10.1109/itsc.2015.65>.
- [47] Bichiou, Y.; Rakha, H.A. Developing an Optimal Intersection Control System for Automated Connected Vehicles. *IEEE Trans. Intell. Transp. Syst.* **2018**, *20*, 1908–1916, <https://doi.org/10.1109/tits.2018.2850335>.
- [48] Bichiou, Y.; Rakha, H.A. Real-time optimal intersection control system for automated/cooperative vehicles. *Int. J. Transp. Sci. Technol.* **2019**, *8*, 1–12, <https://doi.org/10.1016/j.ijst.2018.04.003>.
- [49] Kamalanathsharma, R.K.; Rakha, H. Agent-based modeling of Eco-Cooperative Adaptive Cruise Control systems in the vicinity of intersections. In proceedings of 2012 15th International IEEE Conference on Intelligent Transportation Systems, Anchorage, AK, USA, 16–19 September 2012, <https://doi.org/10.1109/itsc.2012.6338643>.
- [50] Kamalanathsharma, R.K.; Rakha, H.A. Multi-stage dynamic programming algorithm for eco-speed control at traffic signalized intersections. In proceedings of 16th International IEEE Conference on Intelligent Transportation Systems, The Hague, Netherlands, 6–9 October 2013, <https://doi.org/10.1109/itsc.2013.6728538>.
- [51] Kamalanathsharma, R.K.; Rakha, H.A. Fuel-optimal vehicle throttle control: model Logic and preliminary testing. In proceedings of 20th ITS World Congress, Tokyo, Japan, 14–18 October, 2013.

- [52] Kamalanathsharma, R.K.; Rakha, H.A. Leveraging Connected Vehicle Technology and Telematics to Enhance Vehicle Fuel Efficiency in the Vicinity of Signalized Intersections. *J. Intell. Transp. Syst.* **2014**, *20*, 1–12, <https://doi.org/10.1080/15472450.2014.889916>.
- [53] Yang, H.; Rakha, H.; Ala, M.V. Eco-Cooperative Adaptive Cruise Control at Signalized Intersections Considering Queue Effects. *IEEE Trans. Intell. Transp. Syst.* **2016**, *18*, 1–11, <https://doi.org/10.1109/tits.2016.2613740>.
- [54] Yang, H.; Almutairi, F.; Rakha, H. Eco-Driving at Signalized Intersections: A Multiple Signal Optimization Approach. *IEEE Trans. Intell. Transp. Syst.* **2020**, *22*, 2943–2955, <https://doi.org/10.1109/tits.2020.2978184>.
- [55] Almannaa, M.H.; Chen, H.; Rakha, H.A.; Loulizi, A.; El-Shawarby, I. Field implementation and testing of an automated eco-cooperative adaptive cruise control system in the vicinity of signalized intersections. *Transp. Res. Part D: Transp. Environ.* **2018**, *67*, 244–262, <https://doi.org/10.1016/j.trd.2018.11.019>.
- [56] Bradaï, B.; Garnault, A.; Picron, V.; Gougeon, P. A Green Light Optimal Speed Advisor for Reduced CO2 Emissions. In: Langheim, J. (eds) Energy Consumption and Autonomous Driving. Lecture Notes in Mobility. Springer, Cham: New York, NY, USA. https://doi.org/10.1007/978-3-319-19818-7_15.
- [57] Xia, H.; Boriboonsomsin, K.; Schweizer, F.; Winckler, A.; Zhou, K.; Zhang, W.-B.; Barth, M. Field operational testing of ECO-approach technology at a fixed-time signalized intersection. In proceedings of 2012 15th International IEEE Conference on Intelligent Transportation Systems, Anchorage, AK, USA, 16–19 September 2012, <https://doi.org/10.1109/itsc.2012.6338888>.
- [58] Wang, Z.; Wu, G.; Hao, P.; Barth, M.J. Cluster-Wise Cooperative Eco-Approach and Departure Application for Connected and Automated Vehicles Along Signalized Arterials. *IEEE Trans. Intell. Veh.* **2018**, *3*, 404–413, <https://doi.org/10.1109/tiv.2018.2873912>.
- [59] Moser, D.; Waschl, H.; Kirchsteiger, H.; Schmied, R.; del Re, L. Cooperative adaptive cruise control applying stochastic linear model predictive control strategies. In proceedings of 2015 European Control Conference, Linz, Austria, 15–17 July 2015, <https://doi.org/10.1109/ecc.2015.7331057>.
- [60] Bento, L.C.; Parafita, R.; Rakha, H.A.; Nunes, U.J. A study of the environmental impacts of intelligent automated vehicle control at intersections via V2V and V2I communications. *J. Intell. Transp. Syst.* **2018**, *23*, 41–59, <https://doi.org/10.1080/15472450.2018.1501272>.
- [61] Wan, N.; Vahidi, A.; Luckow, A. Optimal speed advisory for connected vehicles in arterial roads and the impact on mixed traffic. *Transp. Res. Part C: Emerg. Technol.* **2016**, *69*, 548–563, <https://doi.org/10.1016/j.trc.2016.01.011>.
- [62] Lee, J.; Park, B. Development and Evaluation of a Cooperative Vehicle Intersection Control Algorithm Under the Connected Vehicles Environment. *IEEE Trans. Intell. Transp. Syst.* **2012**, *13*, 81–90, <https://doi.org/10.1109/tits.2011.2178836>.
- [63] HomChaudhuri, B.; Lin, R.; Pisu, P. Hierarchical control strategies for energy management of connected hybrid electric vehicles in urban roads. *Transp. Res. Part C: Emerg. Technol.* **2016**, *62*, 70–86, <https://doi.org/10.1016/j.trc.2015.11.013>.
- [64] Liu, H.; Lu, X.-Y.; Shladover, S.E. Traffic signal control by leveraging Cooperative Adaptive Cruise Control (CACC) vehicle platooning capabilities. *Transp. Res. Part C: Emerg. Technol.* **2019**, *104*, 390–407, <https://doi.org/10.1016/j.trc.2019.05.027>.
- [65] Lebre, M.A.; Mouël, F.L.; Ménard, E.; Garnault, A.; Bradaï, B.; Picron, V. Real scenario and simulations on GLOSA traffic light system for reduced CO2 emissions, waiting time and travel time. In proceedings of 22nd ITS World Congress, Bordeaux, France, 5–9 October, 2015. <https://doi.org/10.48550/arXiv.1506.01965>.
- [66] Chen, H.; Rakha, H.A. Battery Electric Vehicle Eco-Cooperative Adaptive Cruise Control in the Vicinity of Signalized Intersections. *Energies* **2020**, *13*, 2433, <https://doi.org/10.3390/en13102433>.
- [67] Chen, H.; Rakha, H.A. Developing a Hybrid Electric Vehicle Eco-Cooperative Adaptive Cruise Control System at Signalized Intersections. In proceedings of The 101th Transportation Research Board Annual Meeting, 9–13 January, 2022, Washington D.C., USA.
- [68] Elouni, M.; Abdelghaffar, H.; Rakha, H. Adaptive Traffic Signal Control: Game-Theoretic Decentralized vs. Centralized Perimeter Control. *Sensors* **2021**, *21*, 274, <https://doi.org/10.3390/s21010274>.
- [69] Maile, M.; Delgrossi, L. Cooperative Intersection Collision Avoidance System for Violations (CICAS-V) for Prevention of Violation-Based Intersection Crashes. In proceedings of the 21st International Technical Conference on the Enhanced Safety of Vehicles, Stuttgart, Germany, 15–18 June, 2009.
- [70] McCarthy, B.; O'Driscoll, A. OpenCV2X Mode 4 A Simulation Extension for Cellular Vehicular Communication Networks. In proceedings of 2019 IEEE 24th International Workshop on Computer Aided

Modeling and Design of Communication Links and Networks (CAMAD), Limassol, Cyprus, 11–13 September 2019.

- [71] Sommer, C.; German, R.; Dressler, F. Bidirectionally Coupled Network and Road Traffic Simulation for Improved IVC Analysis. *IEEE Trans. Mob. Comput.* **2010**, *10*, 3–15, <https://doi.org/10.1109/tmc.2010.133>.
- [72] Eckermann, F.; Kahlert, M.; Wietfeld, C. Performance Analysis of C-V2X Mode 4 Communication Introducing an Open-Source C-V2X Simulator. In proceedings of 2019 IEEE 90th Vehicular Technology Conference (VTC2019-Fall), Honolulu, HI, USA, 22–25 September 2019, <https://doi.org/10.1109/vtcfall.2019.8891534>.
- [73] Elbery, A.; Rakha, H.; ElNainay, M.; Hoque, M.A. An Integrated Architecture for Simulation and Modeling of Small- and Medium-Sized Transportation and Communication Networks. In proceedings of 1st International Conference VEHITS 2015, Lisbon, Portugal, 20–22 May 2015, https://doi.org/10.1007/978-3-319-27753-0_16.
- [74] Elbery, A.; Rakha, H.; ElNainay, M.Y.; Hoque, M.A. VNetIntSim - An Integrated Simulation Platform to Model Transportation and Communication Networks. In proceedings of 1st International Conference VEHITS 2015, Lisbon, Portugal, 20–22 May 2015, <https://doi.org/10.5220/0005409401330143>.
- [75] Hoque, M.A.; Hong, X.; Ahmed, S. Parallel Closed-Loop Connected Vehicle Simulator for Large-Scale Transportation Network Management: Challenges, Issues, and Solution Approaches. *IEEE Intell. Transp. Syst. Mag.* **2018**, *11*, 62–77, <https://doi.org/10.1109/imits.2018.2879163>.
- [76] Fernandes, R.; Vieira, F.; Ferreira, M. VNS: An integrated framework for vehicular networks simulation. In proceedings of 2012 IEEE Vehicular Networking Conference (VNC), Seoul, Korea, 14–16 November 2012, <https://doi.org/10.1109/vnc.2012.6407431>.
- [77] Elbery, A., Rakha, H., ElNainay, M. Vehicular communication and mobility sustainability: the mutual impacts in large-scale smart cities. *arXiv preprint*, arXiv:1908.08229.
- [78] Elbery, A.; Rakha, H.A.; ElNainay, M. Large-Scale Modeling of VANET and Transportation Systems. In: Hamdar, S. (eds) Traffic and Granular Flow '17. TGF 2017. Springer, Cham: New York, NY, USA. https://doi.org/10.1007/978-3-030-11440-4_56.
- [79] Farag, M.; Rakha, H.; Mazied, E.; Rao, J. Integration Large-Scale Modeling Framework of Direct Cellular Vehicle-to-All (C-V2X) Applications. *Sensors* **2021**, *21*, 2127, <https://doi.org/10.3390/s21062127>.
- [80] Schiegg, F.A.; Brahmi, N.; Llatser, I. Analytical Performance Evaluation of the Collective Perception Service in C-V2X Mode 4 Networks. In proceedings of 2019 IEEE Intelligent Transportation Systems Conference (ITSC), Auckland, New Zealand, 27–30 Oct. 2019, <https://doi.org/10.1109/itsc.2019.8917214>.
- [81] Segata, M.; Arvani, P.; Cigno, R. A Critical Assessment of C-V2X Resource Allocation Scheme for Platooning Applications. In proceedings of 2021 16th Annual Conference on Wireless On-demand Network Systems and Services Conference (WONS), Klosters, Switzerland, 9–11 March 2021.
- [82] Rajab, S.; Miucic, R. Assessment of Novel V2X Applications Using a Simulation Platform. *SAE Technical Paper*, 2021, <https://doi.org/10.4271/2021-01-0115>.
- [83] Vukadinovic, V.; Bakowski, K.; Marsch, P.; Garcia, I.D.; Xu, H.; Sybis, M.; Sroka, P.; Wesolowski, K.; Lister, D.; Thibault, I. 3GPP C-V2X and IEEE 802.11p for Vehicle-to-Vehicle communications in highway platooning scenarios. *Ad Hoc Networks* **2018**, *74*, 17–29, <https://doi.org/10.1016/j.adhoc.2018.03.004>.
- [84] Malinverno, M.; Raviglione, F.; Casetti, C.; Chiasserini, C.F.; Mangués-Bafalluy, J.; Requena-Esteso, M. A Multi-stack Simulation Framework for Vehicular Applications Testing. In proceedings of the 10th ACM Symposium on Design and Analysis of Intelligent Vehicular Networks and Applications, Alicante, Spain, 16–20 November 2020.
- [85] Mouawad, N.; Mannoni, V.; Denis, B.; da Silva, A.P. Impact of LTE-V2X Connectivity on Global Occupancy Maps in a Cooperative Collision Avoidance (CoCA) System. In proceedings of 2021 IEEE 93rd Vehicular Technology Conference (VTC2021-Spring), Helsinki, Finland, 25–28 April 2021, <https://doi.org/10.1109/vtc2021-spring51267.2021.9449034>.
- [86] Malinverno, M.; Avino, G.; Casetti, C.; Chiasserini, C.F.; Malandrino, F.; Scarpina, S. Performance Analysis of C-V2I-Based Automotive Collision Avoidance. In proceedings of 2018 IEEE 19th International Symposium on "A World of Wireless, Mobile and Multimedia Networks" (WoWMoM), Chania, Greece, 12–15 June 2018, <https://doi.org/10.1109/wowmom.2018.8449772>.
- [87] Magalhaes, P.; D'Orey, P.M.; Andrade, M.T.; Castro, F. Video-assisted Overtaking System Enabled by C-V2X Mode 4 Communications. In proceedings of 2020 16th International Conference on Wireless and Mobile Computing, Networking and Communications (WiMob), Thessaloniki, Greece, 12–14 October 2020, <https://doi.org/10.1109/wimob50308.2020.9253375>.

- [88] An Assessment of LTE-V2X(PC5) and 802.11p direct communications technologies for improved road safety in the EU, 2017. Available Online: <https://5gaa.org/content/uploads/2017/12/5GAA-Road-safety-FINAL2017-12-05.pdf> (accessed on 1 October 2022).
- [89] Rebbeck, T.; Stewart, J.; Lacour, H.A.; Lillen, A.; McClure, D.; Dunoyer, A. Socio-Economic Benefits of Cellular V2X, 2017, Final Report for 5GAA. Available Online: https://5gaa.org/content/uploads/2017/12/Final-report-for-5GAA-on-cellular-V2X-socio-economic-benefits-051217_FINAL.pdf (accessed on 1 October 2022).
- [90] Beyrouthy, K.E.; Löhr, E.; Nokes, T.; Brannigan, C.; Levin, S.; Biedka, M.; Figg, H.; Asselin-Miller, N. Support study for imparc assessment of cooperative intelligent transport systems, *Tech. Rep.* 2018. <https://doi.org/10.2832/067308>.
- [91] Elbery, A.; Rakha, H. City-Wide Eco-Routing Navigation Considering Vehicular Communication Impacts. *Sensors* **2019**, *19*, 290, <https://doi.org/10.3390/s19020290>.
- [92] Elbery, A.; Rakha, H.; Nainay, M. VANET communication and mobility sustainability. In *Connected and Autonomous Vehicles in Smart Cities*. CRC Press: Boca Raton, FL, USA, 2020. p. 30.