

Article

Towards Multiple Sources for Energy Harvesting in Wireless Sensor Networks in Practical Applications

Alberto Coboi¹ , Minh T. Nguyen^{2*}, Ildo Zidane Primeiro¹, Pham Van Nam¹, Bui Van Huy¹, Tien Minh Ta², Thuong TK. Nguyen²

¹Faculty of Electrical and Automation Engineering, Hanoi University of Industry, Hanoi, Vietnam

²Department of Electrical Engineering, Thai Nguyen University of Technology, Thai Nguyen, Vietnam

E-mail: nguyentuanminh@tnut.edu.vn

Received: 13 February 2023; **Revised:** 4 May 2024; **Accepted:** 14 May 2024

Abstract: For wireless sensor networks (WSNs) to continue operating, energy harvesting plays a critical role. This paper explores this topic. WSNs are essential to many applications, from industrial processes to home automation. The difficulty is in giving sensors enough power, particularly in isolated or difficult-to-reach places. A solution is found in energy harvesting, which uses vibration, heat, radio frequency, heat, and solar energy to power sensors. The wide range of uses for energy harvesting in climate change modeling, noise pollution mitigation, and environmental monitoring are examined in this paper. The emphasis now turns to real-world applications of various energy sources to improve WSN performance, with a particular emphasis on the switch from primary to rechargeable batteries. The study emphasizes how battery-free devices can lower maintenance costs and increase application possibilities. The field of energy harvesting, which includes thermal, radiofrequency, vibration, and solar energy, provides access to sustainable and priced WSNs. By elucidating the benefits of battery-free devices, this study underscores the potential to enhance WSN sustainability while simultaneously lowering operational costs. It underscores the transformative impact of energy harvesting, offering a pathway to sustainable and economically viable WSN deployments.

Keywords: wireless sensor networks, energy harvesting, multiple energy sources, environmental monitoring, battery-free devices, sustainable systems

1. Introduction

Devices that can transmit data collected from a monitored field via wireless networks or links depend heavily on wireless sensor networks. The data is routed via numerous nodes and linked to various networks, including Wireless Ethernet and numerous other data transmission methods, via a gateway. Numerous applications, including home automation and control, smart energy, healthcare, industrial process and control, telecommunication, military, agricultural, and electric grid maintenance, are presented in the field of wireless sensor networks.

To gather data, wireless sensor networks are also widely used in locations that are inaccessible to humans. Examples of these locations include radioactive or volcanic sites, chemical and nuclear power plants, numerous locations inside of industries that are inaccessible to humans, pipelines, and flammable gas concentration monitoring [1].

Copyright ©2024 Alberto Coboi, et al.

DOI: <https://doi.org/10.37256/cnc.2120244457>

This is an open-access article distributed under a CC BY license

(Creative Commons Attribution 4.0 International License)

<https://creativecommons.org/licenses/by/4.0/>

The types of networks that can be deployed underwater, underground, on land, and so forth are determined by the specific environment. Wireless sensor networks (WSNs) come in a variety of forms, including mobile, subterranean, underwater, multimedia, and terrestrial. Additionally, the concept of Energy Harvesting in Wireless Sensor Networks is introduced in this paper in the order that is most appropriate given that all the sensors operating in the fields require sufficient power, or in some cases, no batteries at all [2]. Additionally, these sensors face significant limitations when it comes to recharging their batteries when their batteries run low. Finally, there are limitations specific to Wireless Sensor Networks, such as their small storage capacity (a few hundred kilobytes), modest processing power (8 MHz), short communication range, high power consumption, minimal energy-constraint protocols, batteries that have a limited lifespan, and passive devices that provide minimal energy [3, 4].

It is widely known [5] that wireless sensor networks are made to use less power. However, this is insufficient for sensors that are only sent once, and if the battery runs low, that will result in the sensor dying. Fortunately, energy harvesting solves this issue by supplying power through all nearby energy sources, including solar, heat, thermal, radio frequency, and vibration energy harvesting, depending on where the sensor is located [6, 7, 8]. Furthermore, there is a vast array of uses for energy harvesting in wireless sensor networks that take advantage of and support battery limitations and lifespan in areas like to simulate climate change, environmental monitoring is done there [9], where WSNs are used to track carbon dioxide (CO₂) absorption in rain forests. Rain forests are essential to the ecosystem because they generate oxygen and absorb CO₂. monitoring the environment to lessen noise pollution in cities and for other purposes [10, 11, 12].

Therefore, to guarantee that energy harvesting will cause a shift in battery usage from primary to rechargeable batteries for applications that require higher power over the device's lifetime, this paper, Towards Multiple Sources for Energy Harvesting in Wireless Sensor Networks in Practical Applications, is provided. But the real promise is in a new class of battery-free devices that open applications that would have been unaffordable otherwise because of the ongoing maintenance costs associated with changing batteries on a regular basis. The field of energy harvesting is creating technologies to harness a variety of micro power (mill watt) sources, such as solar, vibration, thermal, and radiofrequency energy [8, 13].

In real life, WSNs employ energy harvesting strategies to increase energy output, which serves as a backup source for the networks. As a result, they are categorized as radio frequency energy harvesting, heat, solar, wind, and vibration energy harvesting. And as previously mentioned, this paper goes into detail about how to get energy from the outside world or from renewable sources. To start, it is important to comprehend how each energy harvesting method operates and how it can be used to significant effect in wireless sensor networks.

To convert energy from external sources into electrical charge, electronics devices and an energy source are primarily necessities. Additionally, those electronics devices need to be able to store the obtained charge for as long as possible before converting it into a voltage that can be used to the sensing circuit or even the sensor itself [13, 14]. Consequently, having devices that are intended to rectify the circuit is essential. To achieve this, it is first necessary to figure out how to store the energy that is obtained from outside sources for use in the sensors. Nevertheless, several electronic devices, including transducers, capacitors, and other electronic components, will enable the system to function flawlessly and with high efficiency. To stop the stored energy from being fed back into the source, the circuit rectifier will, in turn, convert AC to DC [15, 16, 17].

Researchers have been asking many questions for a long time, like how we can get enough energy from only one source of energy. Which of these energy sources, natural and renewable, is best suited for use in wireless sensor networks? As a result, we look for answers to these and other questions if we investigate and comprehend the fundamentals of each Energy Harvesting system that is covered in this paper.

Furthermore, this study focuses on investigating various energy harvesting sources to offer a thorough comprehension of the principles of each energy harvesting system. The paper aims to add to the current body of knowledge on energy harvesting in WSNs by addressing these aspects. This paves the way for more investigation into the architecture, operation, strategies, and methods of energy harvesting systems in the sections that follow.

Therefore, this paper is organized into six main sections. The design and workings of Energy Harvesting Systems are explained in detail in Section 2. After that, Section 3 examines Energy Harvesting Techniques, breaking down the benefits and guiding principles of various strategies. We examine the nuances of Energy Harvesting from Multiple Energy Sources

in Section 4, evaluating the opportunities and problems. Section 5 goes on to discuss Energy Harvesting and Storage and investigates ways to maximize energy use. The paper concludes with a thorough analysis and approaches in Section 6.

2. Energy harvesting system

The energy sources for this energy harvesting system are the sun, heat, radio frequency, and even vibrations as it is stated at Figure 1. Following collection, the energy will either be used to stop the stored energy from being fed back into the source or it will pass through a bridge rectifier, which oversees converting the AC voltage to DC voltage. The capacitor regulates both high and low current conditions and supplies the voltage regulator with a balanced signal. The voltage regulator, in turn, supplies the DC-to-DC regulator and transforms the energy from the input storage device into an output storage device by transferring the charge. Nonetheless, aside from an energy source, all energy harvesting systems, in their most basic form, are comprised of three primary parts [16, 17, 18, 19]:

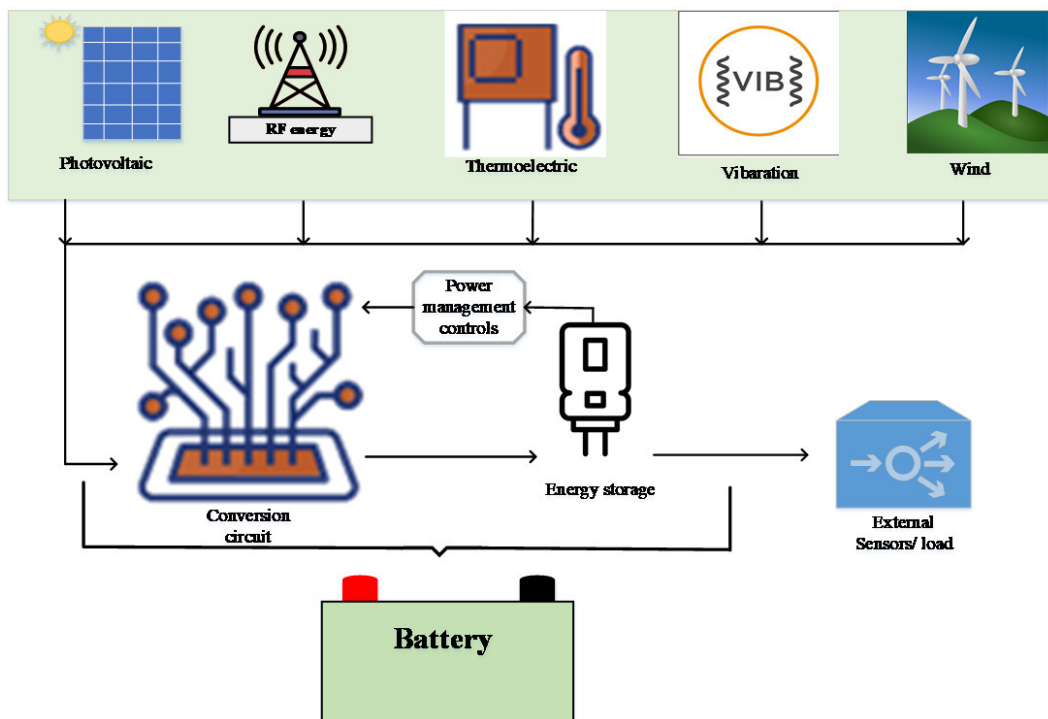

Figure 1. Energy harvesting system

Transducer/Harvester: This is the part of the system that converts the ambient energy from the source into electrical energy.

Interface Circuit: The interface circuit extracts the maximum possible amount of energy from the transducer and makes the energy suitable for use by conditioning it into a suitable form for the desired application (through voltage rectification, voltage regulation, etc.).

Load: The load is the part of the system that could either include electronic devices that consume the harvested energy (such as chips, circuits, actuators, sensors, etc.) or energy storage components such as capacitors, super-capacitors, etc.

3. Energy harvesting techniques

Energy harvesting techniques are used by WSNs in practice to increase energy and support the networks as second sources. However, a thorough understanding of each technique and its primary use in wireless sensor networks is necessary. Since converted energy comes from the environment, it can be stored in a battery for long-term use or a capacitor for short-term use. This eliminates the need for a battery or charger in certain applications. The energy harvesting sector is creating technology to harness a variety of micro power (mill watt) sources, such as solar, vibration, thermal, and radiofrequency energy. The best energy harvesting technology to use for a given installation will, be obvious, but all of them can supply the micro power required for wireless sensor applications, depending on the use case. As a result, the following energy harvesting methods are listed in order of their sources [20, 21, 22].

Table 1 (left) and 1 (right) listing all energy harvesting sources and their primary wireless sensor network characteristics is shown below. The methods and applications of energy harvesting from the source to the sensor's load are also covered.

Table 1 (left). Power available from energy sources and their characteristics energy harvesting in wireless sensor network [7, 17, 18, 19, 20, 21]

Energy Sources	Extraction Technique	Characteristics	Conversion Efficiency	Harvested Power
Solar	Outdoor (direct sun)	Amorphous crystalline		100 mW/cm ²
	Indoor (cloudy day)	Amorphous crystalline	10 to 24%	100 μW/cm ²
Vibration	Hz-Human	Piezoelectric	Source dependent	60 μW/cm ²
	kHz-machines	Piezoelectric		~1 ⁻¹⁰ mW/cm ²
Heat (Thermal)	Human	Thermoelectric Electromagnetic	0.1%	~4 μW/cm ³
	Industrial	Electromagnetic Thermoelectric Piezoelectric	3%	~800 μW/cm ³
Radio Frequency	GSM 900 MHz	Rectenna	50%	0.1 μW/cm ²
	Wi-Fi	Rectenna		0.001 μW/cm ²

Table 1 (right). Power available from energy sources and their characteristics energy harvesting in wireless sensor network [7, 17, 18, 19, 20, 21]

Application	Advantages	Disadvantages
Smart irrigation; fire detector; cameras, etc.	Abundant source of energy	Efficiency affected by weather
Smoke detectors; temperature sensors; etc.	Can be integrated into structures	Limited power output
Biomedical implants.		
Safety of agriculture machinery; automatic pipe monitoring; etc.	Utilizes waste heat	Limited efficiency at small scales
Environmental monitoring.		
Watering metering, precision agriculture.		
Building automation; oil and gas; coin cells; mart Grid; etc.	Long-range wireless charging	Interference with other signals
Building automation; oil and gas; coin cells; mart Grid; etc.	Can charge multiple devices	Power loss over distance

3.1 Energy harvesting with vibration

Vibrations can be used to produce energy in three diverse ways: piezoelectric, electrostatic, and electromagnetic. Energy harvesting via vibration can be categorized as electromagnetic induction, electrostatic, or piezoelectric phenomena. In this process, mechanical energy from a vibrating source in the environment is converted into electric energy using a transducer and a thin piezoceramic material. This vibrating source could be a beam under mechanical stress, which can produce specific vibrations in buildings such as cars passing over a bridge, a train, or even people walking around [23, 24].

These vibrations can be felt anywhere, such as when people are walking, but they are more noticeable in cities due to vehicle traffic on overpasses and bridges as well as factory machinery.

3.2 Piezoelectric energy harvesting

The piezo-electric effect, which transforms mechanical strain from a vibrating mass into electrical current see Figures 2 and 3, is used to extract energy from mechanical vibration. Numerous factors, such as low-frequency seismic vibrations, acoustic noise, and, most frequently, vibration from rotating machinery, can cause this strain. Several electro-mechanical coupling mechanisms have been developed for energy harvesting devices, with a focus on models that use a piezoelectric element to convert mechanical vibrations into electrical current. As a result, internal resonances between the structure's vertical and horizontal vibrating modes may exist in every object that passes through it. the surroundings and are readily triggered by outside stimuli [25, 26].

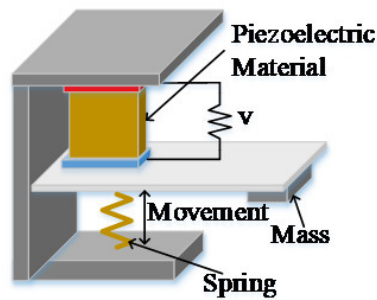

Figure 2. Piezoelectric system

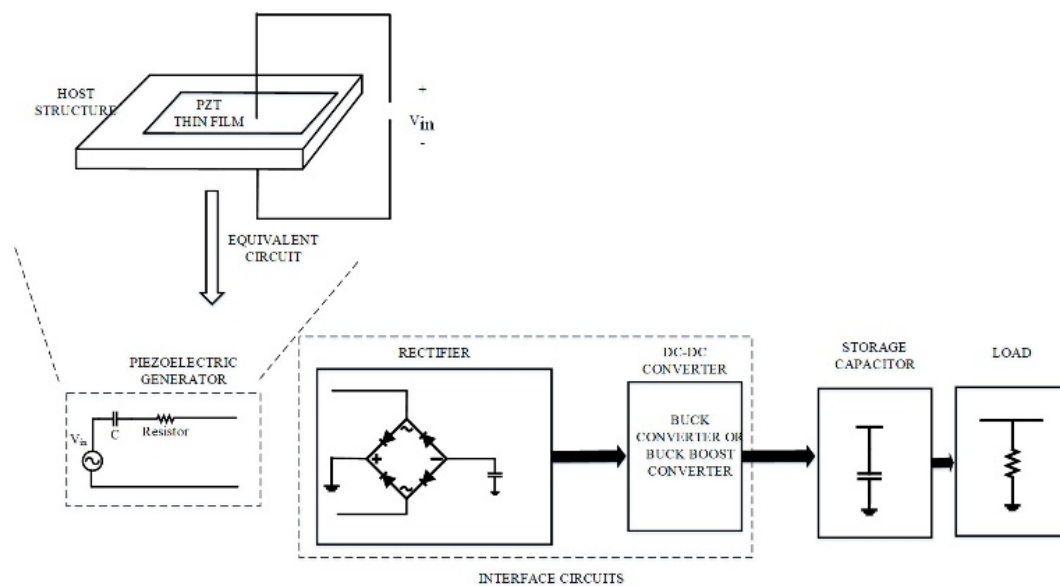

Figure 3. Basic block diagram of piezoelectric energy harvesting

3.3 Electrostatic energy harvesting

The alteration of a vibration dependent variable capacitor's capacitance is the foundation of the electrostatic energy harvesting principle. Two plates, Figures 4 and 5, one fixed and one moving, are placed against each other to create a variable capacitor, which is charged to harvest the mechanical energy. The capacitance changes cause mechanical energy to be converted into electrical energy when the plates vibrate apart. Because these harvesters are compatible with integrated circuits, they can be integrated into microelectronic devices [27]. To charge the capacitor initially, though, you will need

an extra voltage source [28]. There have been recent attempts to prototype sensor-sized electrostatic energy harvesters [29, 30].

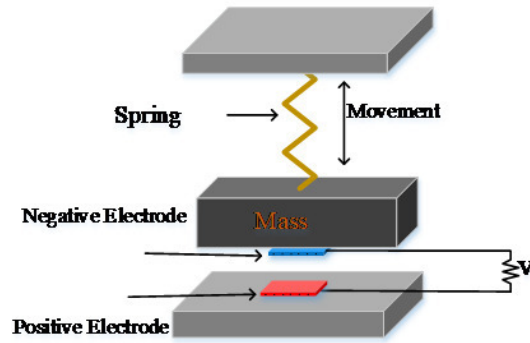

Figure 4. Electrostatic system

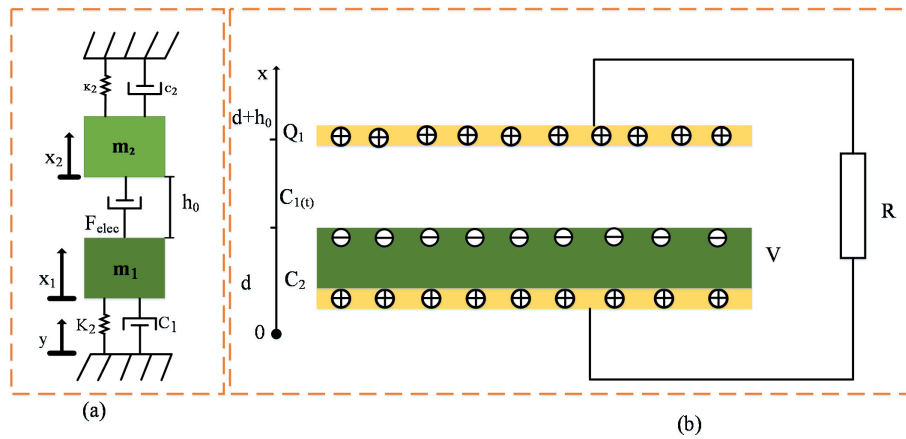

Figure 5. Electrostatic system

The mechanical model a and b, the electrical model of the electrostatic energy harvesting device and the parameters along with their descriptions are presented in Table 2.

Table 2. Parameters of the entire system

Parameters	Description
x_1, x_2 and y	Are the displacement of the external vibration source and the relative displacement of the mass;
k_1, k_2	Spring constant,
F_{elec}	The electrostatic transduction force,
c_1, c_2	The coefficient of viscous damping force,
h_0	Initial gap between two stainless steels,
d	Stainless steel thickness,
Q_1	Induced charge on the upper electrode,
$C_1(t)$	The capacitance of the air gap,
C_2	The capacitance of electret dielectric material,
V	The surface potential of the pre-charged electret,
R	The external load resistance,
m_1, m_2	Bottom and top masses,
F_c	Is the colliding force between the two proof masses.

$$\begin{cases} m_1 (\ddot{y} + \ddot{x}_1) + c_1 \dot{x}_1 + k_1 x_1 + m_1 g + F_{elec} - F_c = 0 \\ m_2 (\ddot{y} + \ddot{x}_2) + c_2 \dot{x}_2 + k_2 x_2 + m_2 g + F_{elec} - F_c = 0 \end{cases} \quad (1)$$

Equation (1) [31], for Figure 5a, is the motion of masses in the dual resonant cantilever system.

$$F_c = \begin{cases} -k_c (h_0 - x_1 + x_2), & \text{for } h_0 - x_1 + x_2 < 0 \\ 0, & \text{for } h_0 - x_1 + x_2 \geq 0 \end{cases} \quad (2)$$

Equation (2) [32], is the complementary to the equation (1), when we want to find the F_c , that is the colliding force between the two proof masses.

$$R \frac{\partial Q_1}{\partial t} = V - Q_1 \left[\frac{1}{c_1(t)} + \frac{1}{C_2} \right] \quad (3)$$

Equation (3) is according to Kirchoff's laws, the differential equation governing the electrostatic system.

3.4 Electromagnetic induction

In AC inductive motors, Figure 6, energy is extracted from the metal windings in the stator and rotor. The actual transducer is a few grams of magnetized mass that is attached to a precisely engineered and adjusted spring. This spring has been calibrated to extract energy from the resonate frequency generated by an alternating current [33].

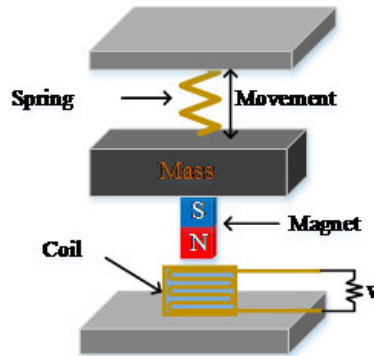

Figure 6. Electromagnetic induction system

Nonetheless, a significant obstacle in vibration-based energy harvesting is [34] determining how to link the frequency of the device we plan to power and the selected source, which could be radio frequency, solar, or another. As per the researchers, it is imperative to depend on methods that can enable frequency stability. Among these methods, magnetic force resonance frequency tuning is considered an ideal option as it involves modifying magnetic stiffness by applying magnetic force in a way that modifies the cantilever beam's effective stiffness [35].

The network operates in two modes: beacon and non-beacon enables modes, which are characterized by the way the medium is accessed [36]. In beaconing mode, the routers send out beacon frames, or signals, on a regular basis to verify their presence on the network. Non-Beaconing Mode: Depending on the application, synchronizing the beacon frames to remove them and keep all devices active always may be more expensive. Direct power to devices or frequent battery changes are the price for this [37, 38, 39].

Because the batteries can self-recharge as soon as the sensors are put into sleep mode, these two aspects must be thoroughly examined to maximize the efficiency of energy harvesting. It is crucial to emphasize that this procedure will be more effective and successful if the sensor is operating in beaconing mode. This will give the capacitor time to build up and recharge enough power so that, should it need to operate, it will do so without any issues [40].

3.5 Energy harvesting with heat

When a device is used for harvesting energy from heat, it can gather and use thermal energy from a temperature gradient. Later, it can be converted to electric energy by means of transducers and capacitors. This temperature gradient can come from a variety of sources, including human skin, home water heating systems, chimneys installed in homes, large production industries that process products that require elevated temperatures, or even places with significant temperature gradients. In a wireless sensor network, heat energy harvesting may be highly effective and provide power output of less than 10 mW/cm^2 [22].

There are various techniques for harvesting heat energy, including the Seebeck effect, also referred to as the Peltier effect. The Peltier effect is thought of as the Seebeck effect's opposite, and the thermoelectric and pyroelectric methods are the result of these two effects.

These two methods are commonly referred to as transducers, which are apparatuses that change physical quantities like pressure and brightness into electronic signals or the other way around. The direct conversion of a temperature differential into electrical voltage and vice versa is known as the thermoelectric effect. When there is a temperature differential between the sides of a thermoelectric device, an electrical voltage is produced [41].

The thermocouple in Figures 7 and 8, the core component of a thermo-electric generator (TEG), is a junction of two distinct semiconductors, one doped with donors (n-type) and the other with acceptors (p-type), that are exposed to two distinct temperatures (T_H and T_C , for hot and cold temperatures, respectively). TEGs are constructed by electrically connecting multiple thermocouples in series and thermally connecting them in parallel because a single thermocouple can only produce small voltages [15].

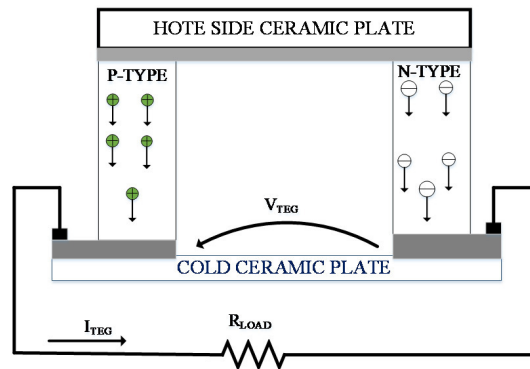

Figure 7. Thermocouple schematic

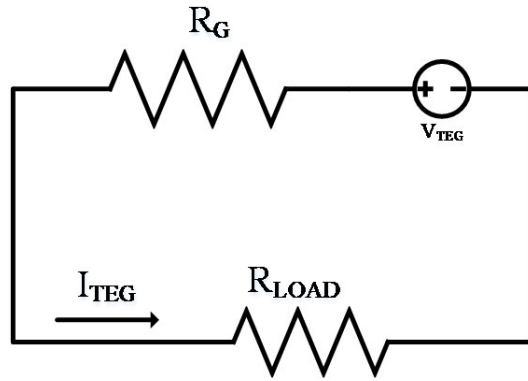

Figure 8. Equivalent electrical circuit of thermocouple schematic

As a first approximation, the TEG equivalent circuit can be modeled in Figure 7 by connecting the TEG internal resistance R_G in series with an ideal voltage generator (V_{TEG}). The current in the circuit can be expressed as follows when the TEG is connected to a resistive load, or R_{LOAD} :

Equation (4):

$$I_{TEG} = \frac{V_{TEG}}{R_{LOAD} + R_G} \quad (4)$$

Equation (5):

$$P_{Load} = R_{Load} * I_{TEG}^2 \quad (5)$$

Equation (6):

$$P_{Load} = \frac{R_{Load}}{R_{Load} + R_G} * V_{TEG}^2 \quad (6)$$

This final one illustrates how, when the load resistance R equals the TEG internal resistance R_G , the power transferred to the load reaches its maximum.

3.6 Thermoelectric energy harvesting

Temperature differences across the material are converted into equivalent electric voltage or electric current using ambient solar energy. A device with a crystal faces two different temperatures, which results in voltage across the crystal. When there is no change in the temperature differential, steady voltage is available. This method uses thermoelectric power generators (TEGs) to produce electric energy from temperature differences, or thermal gradients. The central component of a thermoelectric generator (TEG) is a thermopile, which is made up of arrays of two dissimilar conductors, such as thermocouples (p-type and n-type semiconductors), connected in series between two plates, one hot and one cold [41, 42].

3.7 Pyroelectric energy harvesting

Transform a temperature change into a corresponding electric charge. Crystal material generates electric charge when its temperature varies. At constant temperature, no charge is produced. Certain sensors employ this technique [41, 43].

Regarding the permanence or durability of the power generated, thermoelectric and pyroelectric techniques differ from one another. In the case of the pyroelectric technique, the thermal profile is not fixed, and the current is not uniform.

However, a thermoelectric device directly converts a temperature differential to electrical tension. As a result, when heated or cooled, pyroelectricity briefly produces electrical potential.

Furthermore, the polarization of the material is changed because of this temperature change, which also slightly modifies the atoms' locations within the crystalline structure. A transient electrical potential results from this shift in polarization, and it vanishes after the dielectric relaxation time [44, 45, 46].

3.8 Solar energy harvesting

Solar panels are the most developed technology and have a developed market as an energy source for WSNs. Solar radiation or insolation of the installed location: usually expressed in terms of zones that match a region's average solar intensity. Near the equator are the zones with the highest solar intensity [47, 48].

It is entirely new to use solar energy harvesting as a backup power source for an energy-constrained wireless sensor network (WSN) node. Most mechanical systems are found in environments where solar energy is a green, renewable, and efficient source of energy. High levels of solar radiation can be captured and stored. Nonetheless, the area, climate, and duration of the day all have a significant impact on sunlight. While artificial light has a lower illumination level than sunlight by several orders of magnitude, there is little correlation between artificial light and these factors [48, 49].

The WSN nodes can become fully self-sufficient with an endless network lifetime thanks to the tiny solar panels that are appropriately connected to low-power energy harvester circuits and rechargeable batteries. The sole disadvantage of solar energy is that, depending on the environment, it is only available during business hours or during the entire day. Weather that is cloudy or foggy is another big obstacle to solar energy harvesting, but a battery must be guaranteed to power sensors continuously. In general, solar energy harvesting devices are suitable for outdoor use [50].

An SEH-WSN node's internal block diagram is presented in Figure 9. The WSN node receives a DC power supply (3.6 volts) from the solar energy harvesting system. The solar panels are used to capture this voltage from the surrounding sunshine. Direct conversion of light energy into DC electrical energy occurs within the solar panel. To charge the battery, this DC voltage is regulated by the DC-DC converter. The WSN node is powered by a rechargeable battery. The sensor measurement unit is used by the WSN node to measure the desired physical quantity (such as temperature, light, humidity, and pressure). This sensed data is processed by a microcontroller in the computation unit [47, 51].

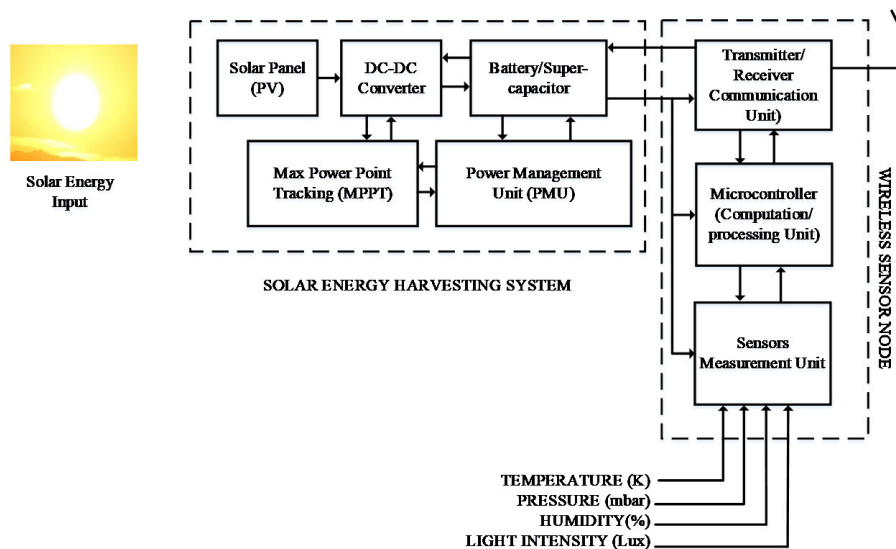

Figure 9. Block diagram of solar energy harvesting wireless sensor network node

3.9 Energy harvesting with wind

The movement of air brought on by variations in air pressure is known as wind; although humans cannot see it, they can feel it. Despite appearing to be a basic aspect of the natural world, wind is made up of complex mechanisms. One of the conventional methods of harvesting wind energy to transfer kinetic energy is through the use of wind turbines, which operate on the electromagnetic induction principle [34, 52]. Large wind turbine generators (WTGs) are used in wind energy harvesting to supply electricity to remote loads and grid-connected applications. In essence, a wind turbine is a very big inverse fan, where wind generates electricity rather than the other way around. However, wind turbines are much more complicated than most fans because they operate “backwards” and weigh between 85 and 400 tons, which is several thousand times more than most fans. This is especially true because it is important to get the best quality and efficiency for the least amount of money. Current wind turbine dimensions are between 40 and 80 meters high, 50 and 85 meters wide, and 850 kW to 4.5 MW in power [53].

Large air masses in motion are the source of wind energy, which is a form of kinetic energy. The kinetic energy of the atmosphere was created when two percent of the solar radiation that fell on Earth’s surface reacted with wind motion, just like it did with temperature, density, and pressure. Energy is produced by the wind, and one of the fastest ways to produce electricity is through wind energy [54].

A power management unit, a wind turbine generator, and an energy harvester that integrates with an electrical generator with the aid of a wind turbine are the three primary components of the wind-powered sensor node. To use the linear motion produced by the wind to produce electricity, a wind turbine of the right size is needed. It is possible to find miniature wind turbines that can generate enough energy to run WSN nodes [55].

The vertical axis turbine in this subsystem is used to harvest wind energy, but in weak wind conditions, its efficiency is not high. Thus, in situations where wind strength is low, the power generation capacity can be increased by employing a wind collection technique to accelerate the wind as it passes through the wind wheel and its system is presented in Figure 10.

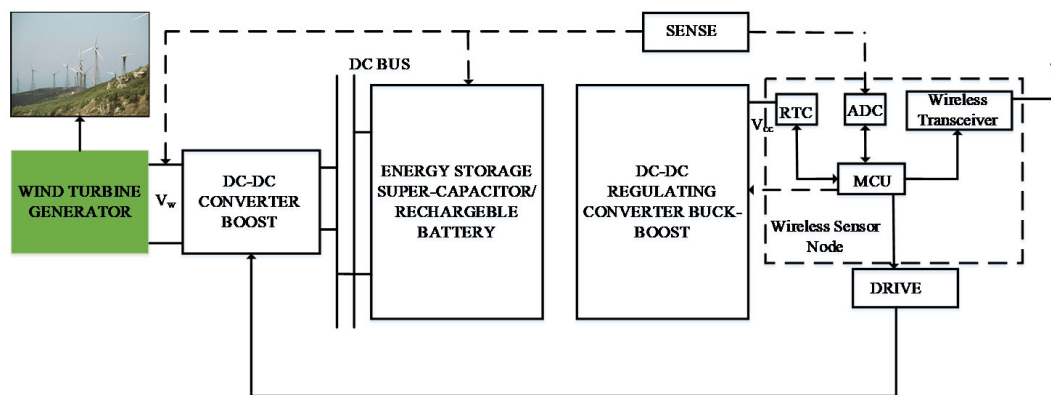

Figure 10. Wind energy based harvesting system

3.10 Energy harvesting with radio frequency

Electrical energy (DC voltage) is produced from the RF signals that the antenna harvests. The wavelength of the signals varies from 0.1 cm to 1000 km, and their frequency ranges from 30 Hz to 300 GHz [26]. Figure illustrates how this is done: radio waves are received using an antenna, the signal is converted, and the output power is conditioned as we see in Figure 11.

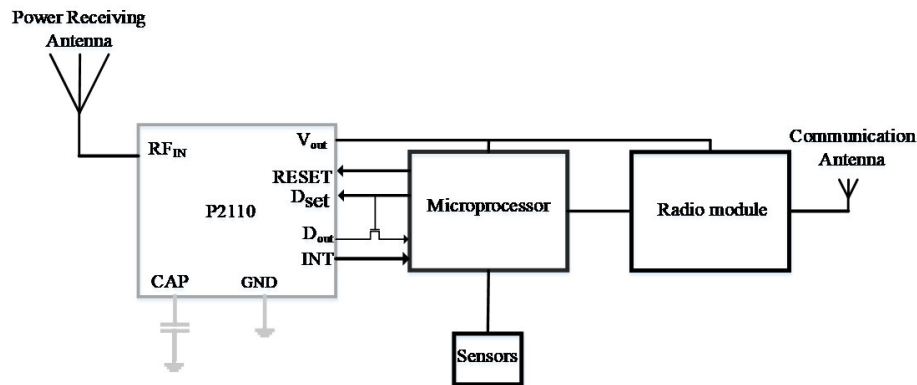

Figure 11. Radio frequency energy based harvesting system

An RF signal can be converted to DC power using a variety of methods, including single-stage and multistage techniques, depending on the desired operating parameter, such as voltage, power, or efficiency. The source power, the distance from the source, the antenna gain, and the conversion efficiency all affects how much power is available for the final device. The components of Power Cast have an average conversion efficiency of 50% to 75% for received RF power over a range of 100X for input power or load resistance, and even higher for specialized applications. There is currently about 100 μ W of harvesting activation power, and the output power can reach 250 mW [56].

3.11 Implementation options

Similar to other energy harvesting techniques, RF energy harvesting can be applied in a variety of ways to the implementation of a power system, such as:

- Direct power (no energy storage);
- Battery-free energy storage (super capacitor);
- Battery-recharging;
- Remote power with battery backup;
- Passive wireless switch (battery activation).

There is a great deal of flexibility in designing power systems for wireless sensors with these implementation options. By using radio frequency energy harvesting, a device can be made to receive power, replenish energy when needed, or activate completely dormant remote sensors [57].

4. Energy harvesting from multiple energy sources

Because natural energy sources are not always available, this frequently leads to subpar performance. As a result, the energy storage buffer (Figure 12) needs to be oversized to store enough energy to keep the system operating even without the energy source. Combining energy from several sources into one design is a more effective strategy. This makes it possible to use the available energy more effectively, but it also presents challenges for the power management circuit's design, which must consider the specific energy source and storage element to optimize the scavenged energy [15, 58].

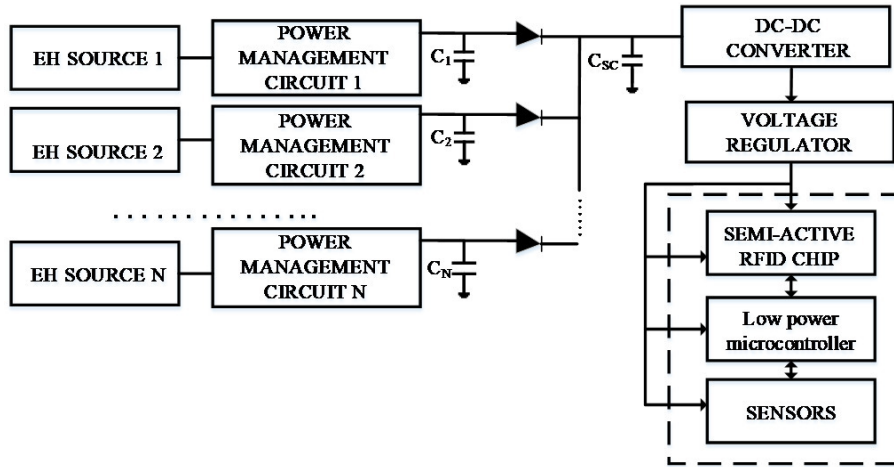

Figure 12. Hybrid energy harvesting system

The overall design of a power management unit intended for energy harvesting, Figure 13. When minimum input power is available, the start-up circuit enables the unit to cold start from zero stored charge. This block can be used with a low-power secondary converter, such as a Dickson charge pump, or it can be implemented as a passive circuit. When the minimum operating value is reached, the under-voltage lockout (UVLO) block, which is monitoring the voltage level at the storage element (VST) during the start-up process, sends a control signal to the main converter to initiate its operation. There are two implementations for the primary converter in the PMU: switched capacitor (SC) or switched inductor [59].

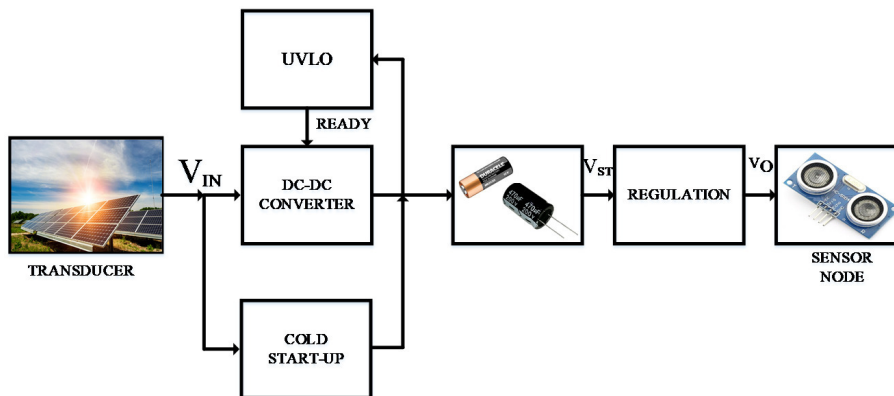

Figure 13. Power management system

4.1 Operation time

The relaying protocol known as time switching based relaying (TSR) allows the receiver to alternate between information processing and energy harvesting.

Transmission ranges and priority balancing can also have an impact on the routing process. A node will not engage in routing if its remaining energy level prevents it from sending a packet with a particular priority. There are several ways that data that is judged not important enough (given the status of the network) can be removed as shown in Figure 14.

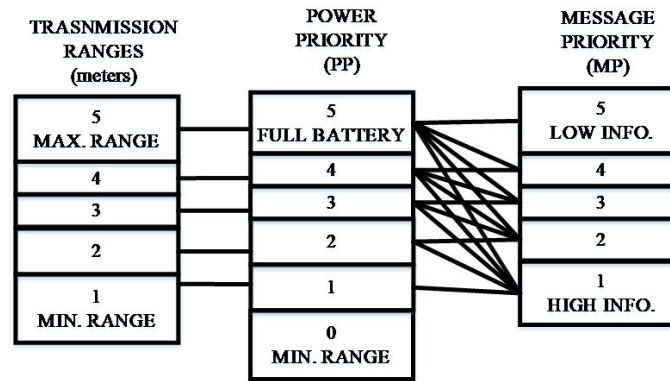

Figure 14. Priority balancing with transmission range

4.2 Event generation

(if a change in the data does not trigger a rule, an event will not be generated), local priority balancing (if the $PP < MP$, the packet will not be created from the generated event),

And routing (if no route exists across the network where $PP \geq MP$ due to loops, the packet will not reach its destination).

5. Energy harvesting storage

5.1 Energy harvesting storage (batteries/supercapacitors)

The converted electrical energy from energy harvesters is unstable and challenging to use as a direct power source for electronic devices due to the inherently unpredictable and unstable characteristics of environmental mechanical, thermal, and solar energy sources. Typically, to stabilize and regulate the power output for direct applications, storage components like capacitors or batteries are required [60].

A power management system that uses energy harvesting must be able to collect, transform, store, and distribute energy in a way that allows the system it supports to use it to generate power. Because of their extended lifespan, high energy and power density, environmental friendliness, and exceptional stability, supercapacitors are the efficient energy storage devices that are widely used in the various energy storage applications. The integration of flexible and microscale super capacitors with other electronic devices, like energy harvesting nano-generators, has been further facilitated by recent advancements in this field [61, 62].

The current wave of wearable electronics and implants of sensors in the human body is typified by a persistent trend toward smaller mobile sensor systems and wireless sensor network nodes. A key component of the system size reduction is the storage device, which can be either a battery or a supercapacitor. In this context, miniaturized energy storage devices with a volume of $1-10 \text{ mm}^3$ and an electrode size in the micrometer range are being thoroughly studied [63].

Microbatteries, microsupercapacitors, and microhybrid metal ion capacitors are the three different categories into which miniature energy storage devices fall. Microbatteries, which share characteristics with conventional batteries such as a high energy density, consistent voltage, and long operational life, are thought to be the most promising option for reduced energy sources in microsystem applications. Conversely, microsupercapacitors have a long cycling life, a high-power density, and a high frequency response. Microhybrid metal ion capacitors have a small footprint, high energy density, and high-power density. They are designed to combine the benefits of supercapacitors and batteries [64].

Because of their DC behavior, solar cells and TEGs can be directly connected to energy storage devices without requiring an electrical circuit. However, because of their AC behavior, pyroelectric and piezoelectric nanogenerators should be connected to energy storage devices that have rectification diodes. Energy harvesters produce erratic and unpredictable electricity, but an energy storage device requires a constant charging voltage and current of the proper value to function.

Thus, to economically charge the energy storage device using energy harvesters, an optimized circuit comprising a capacitor filter, AC–DC, and DC–DC converter is required [65, 66].

In Energy Harvesting-Wireless Sensor Networks, batteries and supercapacitors are the two primary energy storage scheme types. Because they are inexpensive and have a high energy density, supercapacitors are now used as the primary energy storage device for wireless sensor nodes, while batteries are used as the secondary storage device.

A safe and secure energy system based on renewable resources may be possible with the help of battery energy storage. In a wireless sensor network, batteries have the capacity to store renewable energy produced during peak hours and release it when needed. Additionally, batteries can provide more support functions like frequency regulation and voltage control, which helps to keep the Wireless Sensor Network flexible and stable [67].

Supercapacitors are a new type of energy storage technology that can be used in conjunction with energy transfer or harvesting technologies because they have higher power densities and can store excess energy. Unlike batteries, supercapacitors store energy through fast surface redox reactions or electrostatically via ion adsorption (electrochemical double-layer capacitors) see Figure 15.

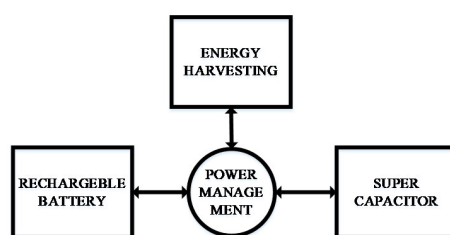

Figure 15. Power model using both rechargeable battery and capacitor

5.2 Charging techniques

The methods for harvesting and transferring energy, as well as the antennas employed, determine how sensor nodes are charged. Several techniques for charging radiofrequency (RF) include distributed beamforming of multiple antennas, cooperative relays, protocol-based optimizations, and multiple antenna transmissions [68].

Based on WiTricity, three charging strategies are put forth that explore the potential for effectively transferring energy over many hops through long-term hybrid energy harvesting. These strategies are as follows:

- The store and forward method rely on nodes having rechargeable batteries installed. Neighboring nodes are charged by the main power source, which is assumed to be stationary, until their batteries run completely empty, or the source reaches a 50% energy threshold. After that, the energy might be moved to the neighbors' next hop's nodes, stored in batteries, and moved to the next hop.
- The direct flow technique operates based on the idea that one node can couple with several nodes at once. Nodes receive energy without storing it in batteries and transmit it straight to the next node by coupling with the nodes before and after them on their path from the source to the destination nodes.
- The store and forward technique and the virtual circuit technique are combined in the hybrid technique. It takes a two-step procedure. The benefit is that the difficulties of charge and discharge losses can be overcome while transferring to multiple hops.

5.3 Analysis and potential approaches

Products with EH technology are already used in certain applications, and new ones are coming up quickly. Large markets like mobile devices, automobiles and trucks, entertainment, UAV networks, health care, infrastructure components,

and smart buildings are full of opportunities. Advancements in energy harvesting can have a significant positive impact on Wireless Sensor Networks for numerous applications [69].

5.4 Energy harvesting in UAV networks

For small unmanned aerial vehicles (UAVs), energy harvesting technology is appealing as it can extend their operating range without requiring a larger fuel system or adding a lot of mass. The idea of vibration and solar energy harvesting using smart materials is taken into consideration to increase the endurance of small UAVs (Figure 16) without significantly increasing their weight. It is suggested that to actively harvest solar energy and vibration, piezoelectric vibration harvesters and photovoltaic solar harvesters be integrated into the aircraft design.

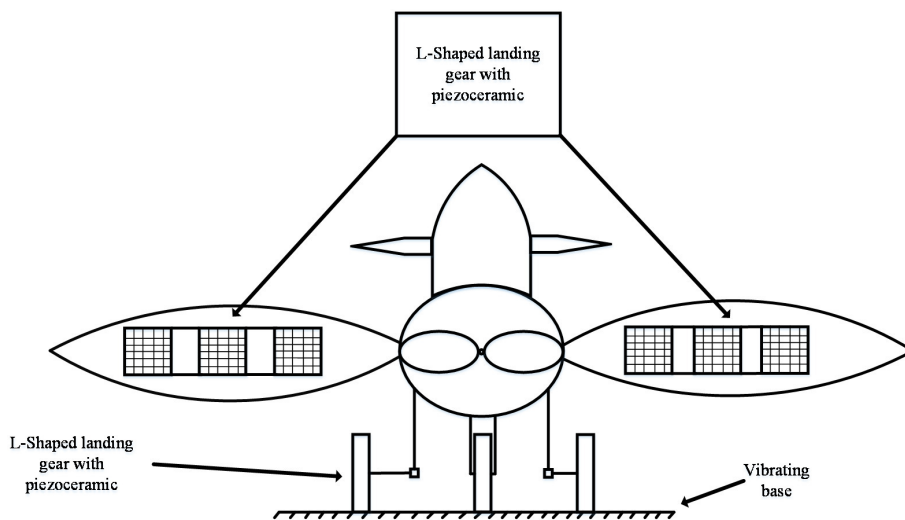

Figure 16. Schematic of a UAV with hybrid energy harvester

5.5 Energy harvesting in UAV networks

Piezoelectric materials, which harvest mechanical energy, and thermoelectric or pyroelectric materials, which harvest thermal energy, are the most promising technologies for energy harvesting for wireless networks, Figure 17 is hybrid energy harvesting for wireless sensor networks.

Applications of energy harvesting in the aerospace and non-aerospace sectors are shown in Figure 18a: A piezoelectric tree concept that uses wind turbulence to capture energy. Figure 18b: Airbus’s proposed thermoelectric seat that harvests energy from passenger body heat. Figure 18c: A solar-powered aircraft that captures solar energy. Figure 18d: A piezoelectric walkway that uses motions made by people to generate energy. A piezoelectric device equipped with knees and uses the motion of the knee to capture energy. Figure 18f: Vehicle equipped with multipurpose structural panels that have the ability to store energy [70].

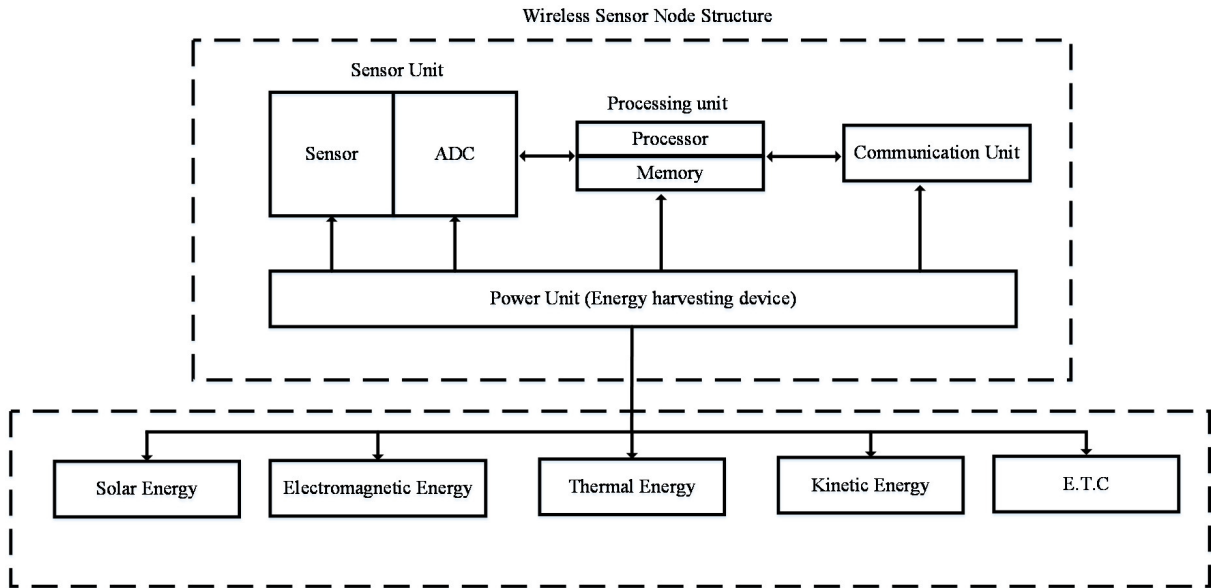

Figure 17. Hybrid energy harvesting for wireless sensor networks

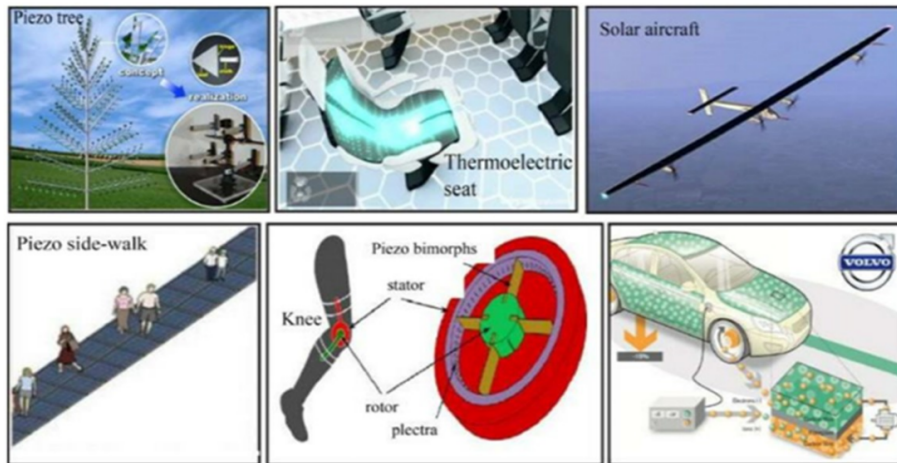

Figure 18. Applications of energy harvesting in the aerospace and non-aerospace sectors

5.6 Energy harvesting as the future of mobile power

This is a functional diagram, Figure 19, that explains how hybrid energy harvesting works. It takes energy from the environment and turns it into direct current power for use in another application. The diagram is based on a patented idea that reuses electromagnetic (EM) energy by using the radio frequency energy from the same mobile phone as an energy-harvesting antenna on its surface [71].

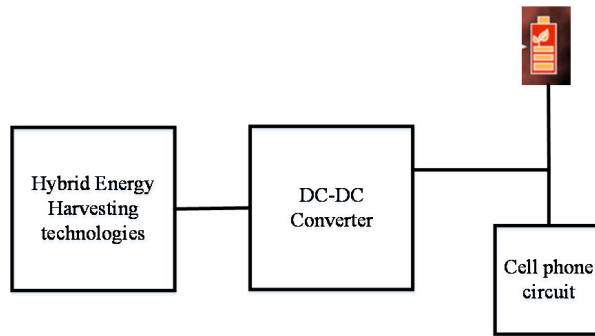

Figure 19. Diagram showing the energy harvesting block of a cell phone

5.7 Socio-economic applications

Energy harvesting technology offers diverse socio-economic applications, Figure 20, that significantly impact both social and economic development. In rural and off-grid areas, the implementation of energy harvesting provides sustainable power sources, elevating living standards and fostering economic activities. Also, the healthcare sector benefits from energy harvesting through power for remote medical devices, improving healthcare delivery and contributing to enhanced health outcomes, boosting economic productivity.

In agriculture, smart farming solutions powered by energy harvesting optimize resource usage, leading to increased crop yield and improved economic returns. The integration of energy harvesting into infrastructure monitoring enhances the maintenance of critical structures, ensuring public safety and preventing economic losses. Wearable technology, fueled by energy harvesting, promotes personal health monitoring, encourages healthier lifestyles, and reduces healthcare costs. Furthermore, energy harvesting plays a pivotal role in education by powering tools in remote areas, bridging educational gaps, and fostering economic opportunities.

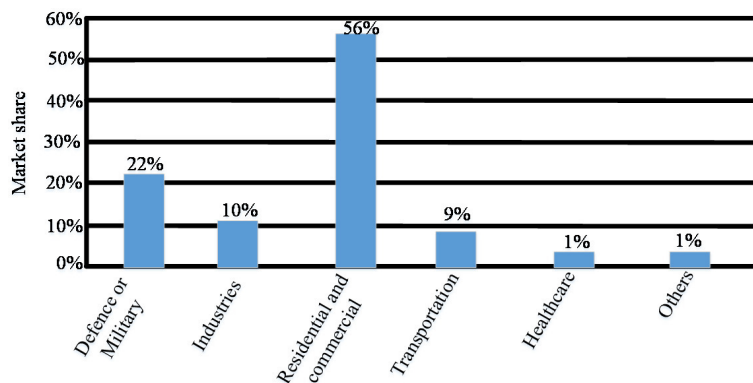

Figure 20. Socio-economic applications of energy harvesting

5.8 Energy harvesting standards

The successful adoption of energy harvesting techniques in various applications hinges on the crucial criterion of interoperability among different end systems. Ensuring seamless communication and compatibility between diverse systems is essential for the effective integration and functionality of energy harvesting technologies across a range of applications. This interoperability facilitates a cohesive and interconnected network, allowing different end systems to work together harmoniously as we see in Figure 21.

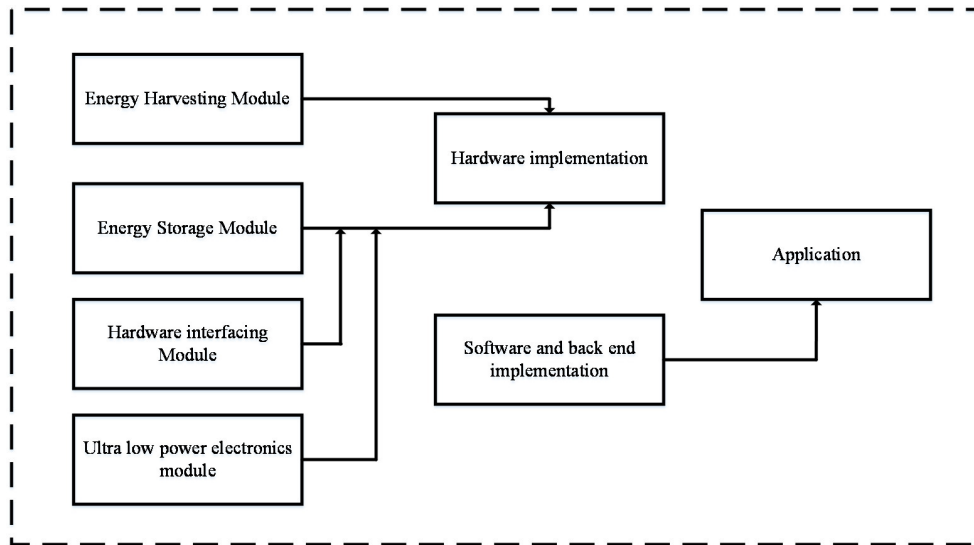

Figure 21. Adaption of energy harvesting techniques in different applications

6. Conclusions and future work

In conclusion, the market for battery power is highly competitive, which emphasizes the necessity of looking into alternate energy sources. This study has shed important light on the harvesting of energy from diverse sources. In the future, we want to concentrate on hybrid energy harvesting, making use of the devices' capacity to simultaneously extract energy from several sources. By using a hybrid approach, we can reduce the possibility of battery or capacitor depletion and guarantee a constant power supply to devices. Furthermore, the system can optimize energy utilization based on individual battery levels thanks to the integration of priorities balancing, as shown in Figure 14. This flexible approach guarantees effective energy management under a range of environmental circumstances.

Moreover, the ability to choose the charging sources according to the current circumstances improves the hybrid energy harvesting system's resilience and autonomy. For example, solar energy can be used in the daytime, and in windy conditions, energy generation can be supplemented by wind or piezoelectric energy harvesting. The shortcomings of conventional battery-powered systems may be addressed by this all-encompassing approach to energy harvesting, which may also open new avenues for producing sustainable electricity.

Acknowledgments

The authors would like to thank Thai Nguyen University of Technology and Hanoi University of Industry, Vietnam for the support.

Conflict of interest

There is no conflict of interest for this study.

References

- [1] M. Faheem, M. W. Ashraf, R. A. Butt, B. Raza, A. Ngadi, and V. C. Gungor, "Ambient Energy Harvesting for Low Powered Wireless Sensor Network based Smart Grid Applications," in *Proc. 2019 7th Int. Istanbul Smart Grids Cities Congr. Fair (ICSG)*, Istanbul, Turkey, Apr. 25–26, 2019, <https://doi.org/10.1109/SGCF.2019.8782404>.
- [2] F. Engmann, F. A. Katsriku, J.-D. Abdulai, K. S. Adu-Manu, and F. K. Banaseka, "Prolonging the Lifetime of Wireless Sensor Networks: A Review of Current Techniques," *Wirel. Commun. Mob. Comput.*, vol. 2018, pp. 1–23, 2018, <https://doi.org/10.1155/2018/8035065>.
- [3] Y. Zhao, M. Ma, C. Miao, and T. Nguyen, "An energy-efficient and low-latency MAC protocol with Adaptive Scheduling for multi-hop wireless sensor networks," *Comput. Commun.*, vol. 33, pp. 1452–1461, 2010, <https://doi.org/10.1016/j.comcom.2010.03.025>.
- [4] S. Jain, P. K. Jain, P. K. Upadhyay, J. M. Moualeu, and A. Srivastava, "An Energy Efficient Health Monitoring Approach with Wireless Body Area Networks," *ACM Trans. Comput. Heal.*, vol. 3, pp. 1–22, 2022, <https://doi.org/10.1145/3501773>.
- [5] M. Faheem, R. A. Butt, B. Raza, M. W. Ashraf, A. Ngadi, and V. C. Gungor, "A multi-channel distributed routing scheme for smart grid real-time critical event monitoring applications in the perspective of Industry 4.0," *Int. J. Ad Hoc Ubiquitous Comput.*, vol. 32, p. 236, 2019, <https://doi.org/10.1504/ijahuc.2019.10024772>.
- [6] C. Viehweger, "Solar energy harvesting for wireless sensor systems," in *Energy Harvesting for Wireless Sensor Networks: Technology, Components and System Design*, Berlin, Germany: De Gruyter, 2019, pp. 37–44, <https://doi.org/10.1515/9783110445053-002>.
- [7] E. Brusa, A. Carrera, and C. Delprete, "A Review of Piezoelectric Energy Harvesting: Materials, Design, and Readout Circuits," *Actuators*, vol. 12, no. 457, 2023, <https://doi.org/10.3390/act12120457>.
- [8] L. Bonati, "Wireless Power Transfer for Next Generation Mobile Networks: Heuristic Policies and their Performance Analysis," M.S. thesis, Univ. Padua, Padua, Italy, Oct. 10, 2016.
- [9] A. R. Dehghani-Sanij, E. Tharumalingam, M. B. Dusseault, and R. Fraser, "Study of energy storage systems and environmental challenges of batteries," *Renew. Sustain. Energy Rev.*, vol. 104, pp. 192–208, 2019, <https://doi.org/10.1016/j.rser.2019.01.023>.
- [10] C. Balantic and T. Donovan, "Dynamic wildlife occupancy models using automated acoustic monitoring data," *Ecol. Appl.*, vol. 29, no. e01854, 2019, <https://doi.org/10.1002/eap.1854>.
- [11] Z. Xuefan, H. Hui, and C. Huimin, "Low-power receiver for wireless sensor networks," in *Proc. IET Conf. Wireless, Mobile Sens. Netw. 2007 (CCWMSN07)*, Shanghai, China, Dec. 12–14, 2007, <https://doi.org/10.1049/cp:20070223>.
- [12] F. Alhuwaishel, N. A. Ahmed, and P. Enjeti, "Active output filter under nonlinear load condition for solar powered unmanned aircraft system," in *Proc. 2017 IEEE 6th Int. Conf. Renewable Energy Res. Appl. (ICRERA)*, San Diego, CA, USA, Nov. 5–8, 2017, <https://doi.org/10.1109/ICRERA.2017.8191080>.
- [13] P. M. Lee, et al., "Methods for powering bioelectronic microdevices," *Bioelectron. Med.*, vol. 1, pp. 201–217, 2018, <https://doi.org/10.2217/bem-2018-0005>.
- [14] M. Grossi, "Energy Harvesting Strategies for Wireless Sensor Networks and Mobile Devices: A Review," *Electronics*, vol. 10, no. 661, 2021, <https://doi.org/10.3390/electronics10060661>.
- [15] C. V. Nguyen et al., "Hybrid Solar-RF Energy Harvesting Systems for Electric Operated Wheelchairs," *Electronics*, vol. 9, no. 752, 2020, <https://doi.org/10.3390/electronics9050752>.
- [16] M. Faheem, M. A. Al-Khasawneh, A. A. Khan, and S. H. H. Madni, "Cyberattack patterns in blockchain-based communication networks for distributed renewable energy systems: A study on big datasets," *Data Brief*, vol. 53, p. 110212, 2024, <https://doi.org/10.1016/j.dib.2024.110212>.
- [17] M. T. Nguyen, H. M. La, and K. A. Teague, "Compressive and collaborative mobile sensing for scalar field mapping in robotic networks," in *Proc. 2015 53rd Annu. Allerton Conf. Commun., Control, Comput.*, Monticello, IL, USA, Sept. 29–Oct. 2, 2015, <https://doi.org/10.1109/ALLERTON.2015.7447098>.
- [18] M. Nguyen, H. Nguyen, A. Masaracchia, and C. Nguyen, "Stochastic-Based Power Consumption Analysis for Data Transmission in Wireless Sensor Networks," *EAI Endorsed Trans. Ind. Netw. Intell. Syst.*, vol. 6, 2019, <https://doi.org/10.4108/eai.13-6-2019.159123>.
- [19] V. R. Challa, M. G. Prasad, Y. Shi, and F. T. Fisher, "A vibration energy harvesting device with bidirectional resonance frequency tunability," *Smart Mater. Struct.*, vol. 17, 2008, <https://doi.org/10.1088/0964-1726/17/01/015035>.

- [20] M. T. Nguyen, C. V. Nguyen, H. T. Tran, and F. Viola, "Energy harvesting for mobile agents supporting wireless sensor networks," *Energy Harvest. Syst.*, vol. 10, pp. 267–275, 2022, <https://doi.org/10.1515/ehs-2022-0086>.
- [21] K. Puniran, R. Ahmad, and R. A. Dziauddin, "RF energy harvesting with multiple sources in wireless sensor network," in *Proc. 2017 IEEE 4th Int. Conf. Smart Instrumentation, Measurement Appl. (ICSIMA)*, Putrajaya, Malaysia, Nov. 28–30, 2017, <https://doi.org/10.1109/ICSIMA.2017.8312005>.
- [22] R. Chéour, M. W. Jmal, O. Kanoun, and M. Abid, "Towards Energy-Efficient Power Management for Wireless Sensors Networks," in *Energy Harvesting for Wireless Sensor Networks*, Berlin, Germany: De Gruyter, 2018, pp. 257–268, <https://doi.org/10.1515/9783110445053-015>.
- [23] M. T. Nguyen, K. A. Teague, and N. Rahnavard, "CCS: Energy-efficient data collection in clustered wireless sensor networks utilizing block-wise compressive sensing," *Comput. Netw.*, vol. 106, pp. 171–185, 2016, <https://doi.org/10.1016/j.comnet.2016.06.029>.
- [24] S. Selvaperumal and C. C. A. Rajan, "Investigation of fuzzy control based LCL resonant converter in RTOS environment," *J. Intell. Fuzzy Syst.*, vol. 26, pp. 913–924, 2014, <https://doi.org/10.3233/IFS-130782>.
- [25] S. Basagni, M. Y. Naderi, C. Petrioli, and D. Spenza, "Wireless sensor networks with energy harvesting," in *Mobile Ad Hoc Networking: Cutting Edge Directions*, 2nd ed., Hoboken, NJ, USA: Wiley-IEEE Press, 2013, pp. 701–736, <https://doi.org/10.1002/9781118511305.ch20>.
- [26] M. N. Rejab, O. M. F. Marwah, M. A. Johar, and M. N. Ribuan, "Real-time Thermal Energy Harvesting from Solar Radiation in Malaysia at Low-Temperature Difference," *J. Adv. Res. Fluid Mech. Therm. Sci.*, vol. 107, pp. 117–132, 2023, <https://doi.org/10.37934/arfmts.107.2.117132>.
- [27] S. K. Gharghan, R. Nordin, and M. Ismail, "Energy-Efficient ZigBee-Based Wireless Sensor Network for Track Bicycle Performance Monitoring," *Sensors*, vol. 14, pp. 15573–15592, 2014, <https://doi.org/10.3390/s140815573>.
- [28] S. Roundy, P. K. Wright, and J. Rabaey, "A study of low level vibrations as a power source for wireless sensor nodes," *Comput. Commun.*, vol. 26, pp. 1131–1144, 2003, [https://doi.org/10.1016/s0140-3664\(02\)00248-7](https://doi.org/10.1016/s0140-3664(02)00248-7).
- [29] D. Niyato, E. Hossain, M. M. Rashid, and V. K. Bhargava, "Wireless sensor networks with energy harvesting technologies: a game-theoretic approach to optimal energy management," *IEEE Wirel. Commun.*, vol. 14, pp. 90–96, 2007, <https://doi.org/10.1109/mwc.2007.4300988>.
- [30] M. Kiziroglou, C. He, and E. Yeatman, "Flexible substrate electrostatic energy harvester," *Electron. Lett.*, vol. 46, pp. 166–167, 2010, <https://doi.org/10.1049/el.2010.2462>.
- [31] E. Barati, M. R. Zarkak, and M. Biabani, "Investigating the effect of the flow direction on heat transfer and energy harvesting from induced vibration in a heated semi-circular cylinder," *Ocean Eng.*, vol. 279, 2023, <https://doi.org/10.1016/j.oceaneng.2023.114487>.
- [32] F. Santangelo, G. Failla, A. Santini, and F. Arena, "Time-domain uncoupled analyses for seismic assessment of land-based wind turbines," *Eng. Struct.*, vol. 123, pp. 275–299, 2016, <https://doi.org/10.1016/j.engstruct.2016.05.043>.
- [33] R. Ahmed, S. Draskovic, and L. Thiele, "Stochastic Guarantees for Adaptive Energy Harvesting Systems," *IEEE Trans. Comput. Des. Integr. Circuits Syst.*, vol. 41, pp. 3614–3625, 2022, <https://doi.org/10.1109/tcad.2022.3198519>.
- [34] A. E. Coboi, V. Nguyen, M. Nguyen, N. DUY, and T. TRAN, "An Analysis of ZigBee Technologies for Data Routing in Wireless Sensor Networks," *ICSES Trans. Comput. Netw. Commun.*, vol. 7, pp. 5–14, 2021.
- [35] A. M. Gaouda, F. Sallabi, A. H. El-Hag, and M. M. A. Salama, "Zigbee performance during severe interruptions in electric power systems," in *Proc. 2011 11th Int. Conf. Electrical Power Quality Utilisation (EPQU)*, Lisbon, Portugal, Oct. 17–19, 2011, <https://doi.org/10.1109/EPQU.2011.6128884>.
- [36] B. Purnama, R. Budiarto, D. Stiawan, and D. Hanapi, "Monitoring Connectivity of Internet of Things Device on Zigbee Protocol," in *Proc. 2018 Int. Conf. Electr. Eng. Comput. Sci. (ICECOS)*, Pangkal, Indonesia, Oct. 2–4, 2018, <https://doi.org/10.1109/ICECOS.2018.8605225>.
- [37] A. Coboi, M. T. Nguyen, V. N. Pham, T. C. Vu, M. D. Nguyen, and D. T. Nguyen, "Zigbee Based Mobile Sensing for Wireless Sensor Networks," *Comput. Netw. Commun.*, pp. 325–342, 2023, <https://doi.org/10.37256/cnc.1220233923>.
- [38] S. Chamanian, B. Çiftci, H. Uluşan, A. Muhtaroglu, and H. Külah, "Power-efficient hybrid energy harvesting system for harnessing ambient vibrations," *IEEE Trans. Circuits Syst. I: Regul. Pap.*, vol. 66, pp. 2784–2793, 2019, <https://doi.org/10.1109/TCSI.2019.2900574>.
- [39] M. T. Nguyen and K. A. Teague, "Neighborhood based data collection in Wireless Sensor Networks employing Compressive Sensing," in *Proc. 2014 Int. Conf. Adv. Technol. Commun. (ATC)*, Hanoi, Vietnam, Oct. 15–17, 2014, <https://doi.org/10.1109/ATC.2014.7043383>.

- [40] C. Lu, V. Raghunathan, and K. Roy, "Micro-scale energy harvesting: A system design perspective," in *Proc. 2010 15th Asia South Pac. Des. Autom. Conf. (ASP-DAC)*, Taipei, Taiwan, Jan. 18–21, 2010, <https://doi.org/10.1109/ASPDAC.2010.5419913>.
- [41] C. R. Bowen, J. Taylor, E. LeBoulbar, D. Zabek, A. Chauhan, and R. Vaish, "Pyroelectric materials and devices for energy harvesting applications," *Energy Environ. Sci.*, vol. 7, pp. 3836–3856, 2014, <https://doi.org/10.1039/c4ee01759e>.
- [42] S. A. Tahami, M. Gholikhani, and S. Dessouky, "Thermoelectric Energy Harvesting System for Roadway Sustainability," *Transp. Res. Rec. J. Transp. Res. Board*, vol. 2674, pp. 135–145, 2020, <https://doi.org/10.1177/0361198120905575>.
- [43] G. Sebald, D. Guyomar, and A. Agbossou, "On thermoelectric and pyroelectric energy harvesting," *Smart Mater. Struct.*, vol. 18, 2009, <https://doi.org/10.1088/0964-1726/18/12/125006>.
- [44] S. R. Hunter, N. V. Lavrik, P. G. Datskos, and D. Clayton, "Pyroelectric Energy Scavenging Techniques for Self-Powered Nuclear Reactor Wireless Sensor Networks," *Nucl. Technol.*, vol. 188, pp. 172–184, 2014, <https://doi.org/10.13182/nt13-136>.
- [45] H. Sharma, A. Haque, and Z. A. Jaffery, "Modeling and Optimisation of a Solar Energy Harvesting System for Wireless Sensor Network Nodes," *J. Sens. Actuator Netw.*, vol. 7, p. 40, 2018, <https://doi.org/10.3390/jsan7030040>.
- [46] C. Alippi and C. Galperti, "An Adaptive System for Optimal Solar Energy Harvesting in Wireless Sensor Network Nodes," *IEEE Trans. Circuits Syst. I Regul. Pap.*, vol. 55, pp. 1742–1750, 2008, <https://doi.org/10.1109/tcsi.2008.922023>.
- [47] P. Sundriyal and S. Bhattacharya, "Energy Harvesting Techniques for Powering Wireless Sensor Networks in Aircraft Applications: A Review," in *Sensors for Automotive and Aerospace Applications*, Berlin, Germany: Springer, 2019, pp. 55–76, https://doi.org/10.1007/978-981-13-3290-6_4.
- [48] F. K. Shaikh and S. Zeadally, "Energy harvesting in wireless sensor networks: A comprehensive review," *Renew. Sustain. Energy Rev.*, vol. 55, pp. 1041–1054, 2016, <https://doi.org/10.1016/j.rser.2015.11.010>.
- [49] T. Quyen, C. Nguyen, A. Le, and M. Nguyen, "Optimizing Hybrid Energy Harvesting Mechanisms for UAVs," *EAI Endorsed Trans. Energy Web*, 2018, <https://doi.org/10.4108/eai.13-7-2018.164629>.
- [50] Q. Huang, X. Li, M. Shaurette, and R. F. Cox, "Novel Sensor Network Architecture for Intelligent Building Environment Monitoring and Management," *Comput. Civ. Eng.*, pp. 347–354, 2011, [https://doi.org/10.1061/41182\(416\)43](https://doi.org/10.1061/41182(416)43).
- [51] G. Hu, K. Tse, M. Wei, R. Naseer, A. Abdelkefi, and K. Kwok, "Experimental investigation on the efficiency of circular cylinder-based wind energy harvester with different rod-shaped attachments," *Appl. Energy*, vol. 226, pp. 682–689, 2018, <https://doi.org/10.1016/j.apenergy.2018.06.056>.
- [52] M. T. Nguyen and K. A. Teague, "Compressive sensing based energy-efficient random routing in wireless sensor networks," in *Proc. 2014 Int. Conf. Adv. Technol. Commun. (ATC)*, Hanoi, Vietnam, Oct. 15–17, 2014, <https://doi.org/10.1109/ATC.2014.7043381>.
- [53] M. T. Nguyen and K. A. Teague, "Compressive sensing based random walk routing in wireless sensor networks," *Ad Hoc Netw.*, vol. 54, pp. 99–110, 2017, <https://doi.org/10.1016/j.adhoc.2016.10.009>.
- [54] M. T. Nguyen and K. A. Teague, "Tree-based energy-efficient data gathering in wireless sensor networks deploying compressive sensing," in *Proc. 2014 23rd Wireless Opt. Commun. Conf. (WOCC)*, Newark, NJ, USA, May 9–10, 2014, <https://doi.org/10.1109/WOCC.2014.6839920>.
- [55] C. Lu, C.-Y. Tsui, and W.-H. Ki, "Vibration Energy Scavenging System With Maximum Power Tracking for Micropower Applications," *IEEE Trans. Very Large Scale Integr. (VLSI) Syst.*, vol. 19, pp. 2109–2119, 2010, <https://doi.org/10.1109/tvlsi.2010.2069574>.
- [56] S. Panda, et al., "Piezoelectric energy harvesting systems for biomedical applications," *Nano Energy*, vol. 100, 2022, <https://doi.org/10.1016/j.nanoen.2022.107514>.
- [57] H. Sun, Y. Zhang, J. Zhang, X. Sun, and H. Peng, "Energy harvesting and storage in 1D devices," *Nat. Rev. Mater.*, vol. 2, p. 17023, 2017, <https://doi.org/10.1038/natrevmats.2017.23>.
- [58] C. Lu, S. P. Park, V. Raghunathan, and K. Roy, "Stage number optimization for switched capacitor power converters in micro-scale energy harvesting," in *Proc. 2011 Des. Autom. Test Eur. (DATE)*, Grenoble, France, Mar. 14–18, 2011, <https://doi.org/10.1109/DATE.2011.5763131>.
- [59] M. Song, Y. Zhang, M. Peng, and J. Zhai, "Low frequency wideband nano generators for energy harvesting from natural environment," *Nano Energy*, vol. 6, pp. 66–72, 2014, <https://doi.org/10.1016/j.nanoen.2014.02.009>.

- [60] P. Lu, D. Xue, H. Yang, and Y. Liu, "Supercapacitor and nanoscale research towards electrochemical energy storage," *Int. J. Smart Nano Mater.*, vol. 4, pp. 2–26, 2013, <https://doi.org/10.1080/19475411.2013.775667>.
- [61] H. T. Tran, C. V. Nguyen, N. T. Phung, and M. T. Nguyen, "Mobile agents assisted data collection in wireless sensor networks utilizing ZigBee technology," *Bull. Electr. Eng. Inform.*, vol. 12, pp. 1127–1136, 2023, <https://doi.org/10.11591/eei.v12i2.4541>.
- [62] S. H. Choday, C. Lu, V. Raghunathan, and K. Roy, "On-chip energy harvesting using thin-film thermoelectric materials," in *Proc. 2013 IEEE/CPMT 29th Semicond. Therm. Meas. Manag. Symp. (SemiTherm 2013)*, San Jose, CA, USA, Mar. 17–21, 2013, <https://doi.org/10.1109/SEMI-THERM.2013.6526812>.
- [63] R. Hahn, J. König, P. Spies, M. Pollak, and L. Mateu, "Thermoelectric generators," in *Handbook of Energy Harvesting Power Supplies and Applications*, Singapore, Singapore: Jenny Stanford Publishing, 2015, pp. 217–257.
- [64] A. Malik, M. Z. Khan, S. M. Qaisar, M. Faisal, and G. Mehmood, "An Efficient Approach for the Detection and Prevention of Gray-Hole Attacks in VANETs," *IEEE Access*, vol. 11, pp. 46691–46706, 2023, <https://doi.org/10.1109/access.2023.3274650>.
- [65] W. Cheng, Y. Li, Y. Jiang, X. Yin, and D. Li, "An improved routing scheme for wireless sensor networks with Hybrid Energy Storage System," in *Proc. 2015 IEEE 10th Conf. Ind. Electron. Appl. (ICIEA)*, Auckland, New Zealand, Jun. 15–17, 2015, <https://doi.org/10.1109/ICIEA.2015.7334101>.
- [66] M. T. Nguyen, H. T. Tran, C. V. Nguyen, G. Ala, F. Viola, and I. Colak, "A Novel Framework of Hybrid Harvesting Mechanisms for Remote Sensing Devices," in *Proc. 2022 IEEE 21st Mediterr. Electrotech. Conf. (MELECON)*, Palermo, Italy, Jun. 14–16, 2022, <https://doi.org/10.1109/MELECON53508.2022.9842963>.
- [67] M. T. Nguyen and K. A. Teague, "Distributed DCT based data compression in clustered wireless sensor networks," in *Proc. 2015 11th Int. Conf. Des. Reliab. Commun. Netw. (DRCN)*, Kansas City, MO, USA, Mar. 24–27, 2015, <https://doi.org/10.1109/DRCN.2015.7149022>.
- [68] C. Y. Chen and P. H. Chou, "DuraCap: A supercapacitor-based, power-bootstrapping, maximum power point tracking energy-harvesting system," in *Proc. 16th ACM/IEEE Int. Symp. Low Power Electron. Des.*, Austin, TX, USA, Aug. 18–20, 2010, <https://doi.org/10.1145/1840845.1840910>.
- [69] A. E. Cobo, T. A. Tran, S. Q. Tran, and M. T. Nguyen, "Security Problems in Smart Homes," *ICSES Trans. Comput. Netw. Commun.*, vol. 2021, pp. 1–9, In Press.
- [70] X. Tang, X. Wang, R. Cattley, F. Gu, and A. D. Ball, "Energy Harvesting Technologies for Achieving Self-Powered Wireless Sensor Networks in Machine Condition Monitoring: A Review," *Sensors*, vol. 18, p. 4113, 2018, <https://doi.org/10.3390/s18124113>.
- [71] P. Spies, M. Pollak, and G. Rohmer, "Energy harvesting for mobile communication devices," in *Proc. INTELEC 07–29th Int. Telecommun. Energy Conf.*, Rome, Italy, Sep. 30–Oct. 4, 2007, <https://doi.org/10.1109/INTLEC.2007.4448826>.