



Article

Uncovering Gas Insulated Substation Transient Behaviours Using the Equivalent Cable Model

Hassan Nouri^{1,*}, Alexandru Muresan², Levente Czumbi² and Dan Micu²

¹School of Engineering, Power Systems Research Laboratory, University of West of England, Bristol, BS16 1QY, UK

²Faculty of Electrical Engineering, Technical University of Cluj-Napoca, Cluj-Napoca, Romania

E-mail: Hassan.Nouri@uwe.ac.uk

Received: 5 April 2023; Revised: 31 May 2023; Accepted: 5 June 2023

Abstract: An improved circuit theory approach is proposed for verification of data obtained with the Electro-Magnetic Field (EMF) theory for the study of Gas Insulated Substations (GIS) transient behaviours. The improved circuit theory utilises the concept of an equivalent cable model. The proposed equivalent cable model reduces time and eliminates costs associated with experimentation, which in some cases is not feasible. Also reported is the degree of accuracy in using the proposed model as a benchmark for verification purposes.

Keywords: EMF theory, circuit theory, HALD model, GIS, PEEC

1. Introduction

Lightning impulses and operation of switches in Gas Insulated Substations (GIS) generate Very Fast Transient Over voltages (VFTO) that can affect the proper operation of the encapsulated substation [1,2]. VFTO within the GIS enclosure are characterized by oscillatory phenomena with very high frequencies (up to 100 MHz) and with maximum amplitudes up to 1.7 p.u [3]. The fault occurs between the phase conductor and the metallic enclosure when the amplitude of the generated VFO becomes greater than the Lightning Impulse Withstand Voltage of the substation [4]. Several modelling techniques applied to GIS transient behaviour that exist are based on circuit theory and electromagnetic field theory [5–7]. The numerical electromagnetic field method can deal with both transversal electromagnetic propagation mode (TEM) and non-TEM propagation mode [8]. The circuit theory-based modelling of electrical components utilises a lumped or distributed model [9]. This approach allows the wave retardation mode to be neglected and only TEM propagation mode to be included [10].

The impetus of this work arose from the need to validate the transient output of a simple GIS model composed of a conductor within its metal enclosure (Legend 8 in Figure 1) constructed in the newly developed and dedicated EMF XGSLab software [11]. The XGSLab software uses a Partial Equivalent Element Circuit (PEEC) electromagnetic numerical approach. The traditional experimental validation route is expensive, time consuming and may not be possible in all cases. Hence, with the availability of graphical interface facilities in most transient software, this work aims to complement the previous circuit theory analysis applied for Gas Insulated Substation behaviour [4]. This is achieved by introducing the concept of a frequency dependent equivalent cable model which uses a quasi-TEM approach, that is named here as the HALD GIS model. Within an acceptable degree of error (less than 10%), comparisons of transient data, such as Transient Grand Potential Rise (TGPR), Very Fast Transient (VFT) over-voltages, or the dielectric breakdown, at locations along the conductor inside the GIS metallic enclosure from both methodologies will confirm the viability of the proposed procedure.

Section 2 of the paper discusses the modelling approaches in PSCAD and XGSLab software, and section 3 demonstrates validation results of the EMF GIS model with the HALD model. Finally, section 4 concludes this investigation.

2. Modelling Technique

The proposed approach considers only the faulted phase conductor of a three-phase, double wall type, Gas Insulated Substation, during the computational process. The GIS busbar of Figure 1 is connected through 20 m long, single core, power cables (ACSR 36/7) to a 110 kV overhead transmission line, as shown in the equivalent EMF model of Figure 2. A direct lightning strike to the power cable is considered to produce a breakdown in the GIS enclosure that mimics a phase-to-enclosure fault.

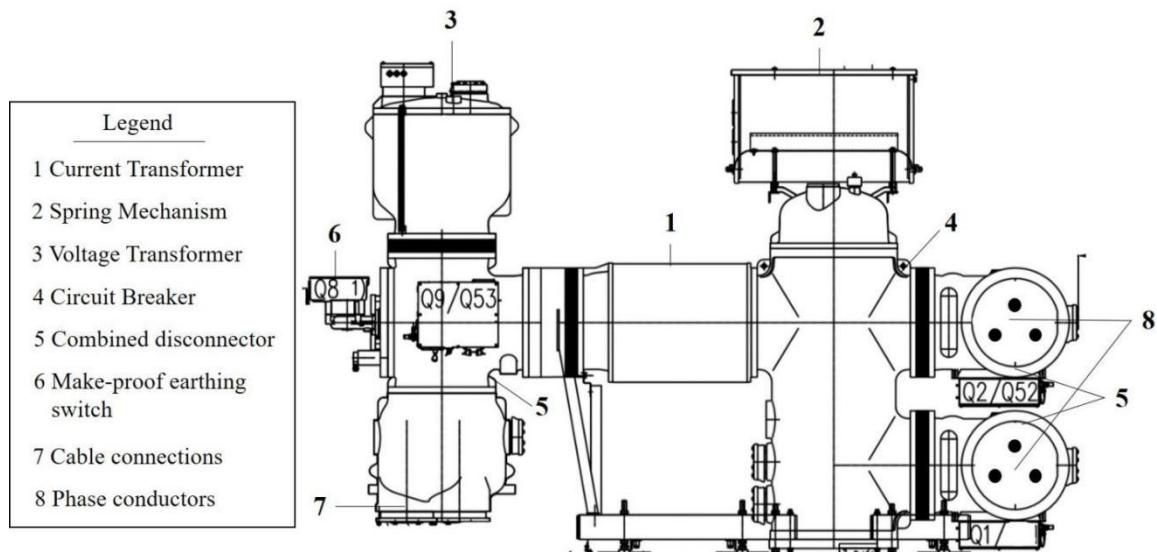

Figure 1. Physical model of a 110 KV substation.

As a first step towards uncovering the nature of transients in GIS, a simplified geometry of the GIS (Legend 8 in Figure 1) illustrated in Figure 2, is constructed in both EMF XGSLab and PSCAD software. Similar to the previous reported work [4], here also one conductor of the three phase conductors is used for this investigation.

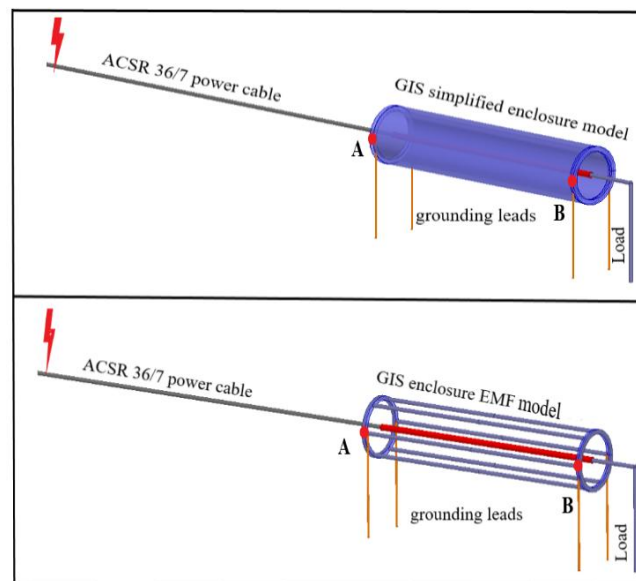

Figure 2. Equivalent EMF model implemented in PSCAD and XGSLab software.

2.1 Equivalent EMF Model Description

The implemented Electro-Magnetic Field (EMF) theory approach utilises the concept of the Partial Element Equivalent Circuit (PEEC). The PEEC solver infers the Maxwell equations to a circuit domain by calculating the resistance, inductance, capacitance and conductance of the 3-dimensional metal, dielectric objects and consequently the corresponding S-parameters matrix.

For EMF modelling of the GIS section of Figure 1 in the XGSLab software [11], the GIS enclosure is made of 6 aluminium bars (in a hexagon-shape geometry) parallel to the ground as shown in Figure 2. The thickness of the aluminium represents the enclosure depth. A detailed and comprehensive modelling procedure and overview is discussed in Mureşan's PhD thesis [12]. Table 1 shows the geometry and material data of the model.

Table 1. Geometry and material of model components.

Model Components	Components Diameter [mm]	Components Material
BUS of Phase A	100	Copper
Aluminium Bars	40	Aluminium
ACSR 36/7 cable	36	Aluminium

2.2 Cable Model for GIS Representation: The HALD Model

In the proposed model shown in Figure 3, the metallic enclosure and its contents are modelled as a coaxial cable. The core represents the phase conductor, SF6 as insulator 1, and the sheath represents the GIS enclosure (inner, outer wall and the space between them) which is considered to be a solid aluminium pipe with a thickness of 40 mm. The air with radius of 1m that surrounds the GIS is modelled as insulator 2. This concept is named as the HALD model.

At short lengths of GIS, considering the speed of wave propagation (300,000 Km/s), reflections and refractions can occur due to variations of characteristic impedance on the propagation path. To avoid numerical instabilities and reflections phenomena, the matching impedance with the same value as the computed total impedance of the system needs to be set as the load. Also, an appropriate simulation time step needs to be selected.

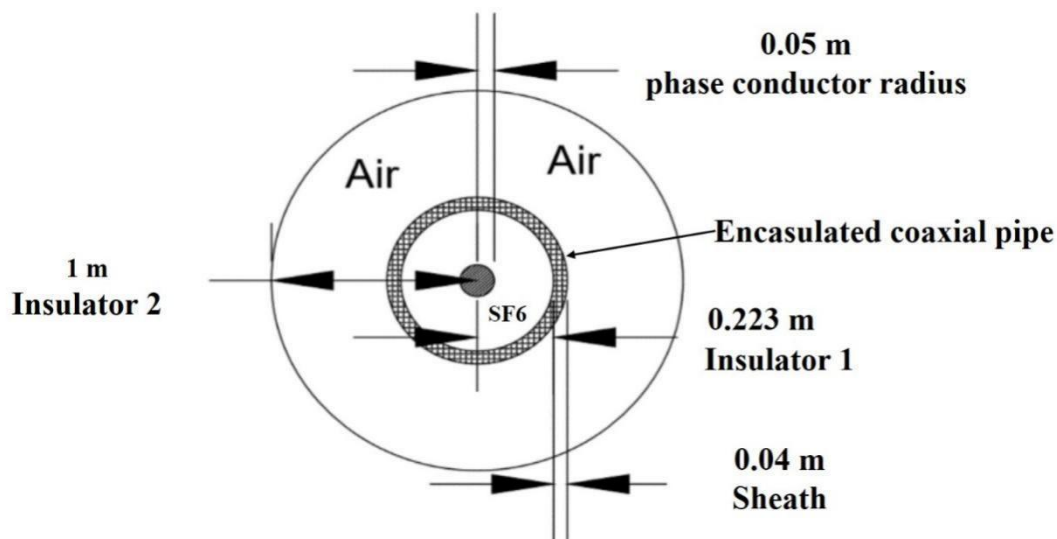

Figure 3. A four-layer co-axial cable Model representing one conductor of the phase conductors shown in figure 1.

3. Comparison of EMF and HALD Results

The phase conductor part of GIS (Legend 8 in Figure 1) described in section 2 is simulated with both HALD and EMF approaches. The 2 m GIS busbar which represents the single-phase conductor is divided into two 1 m long sections. The same electrical and geometrical parameters in terms of diameter, length, and insulation material are used in both XGSLab and PSCAD software. In both cases, the GIS enclosure is

connected to the grounding grid via four, $1\text{ m}\Omega$ resistors. The 20 m single core incoming line is modelled as a 2-layer, co-axial cable. The transient analysis is performed for the GIS when it is subjected to the lightning surge of 30 kA , $1/50\text{ }\mu\text{s}$ with double exponential waveform defined in [4]. The breakdown in the GIS SF6 insulation is represented by a short-circuit fault between the phase conductor and the GIS enclosure. Figure 4 represents the PSCAD frequency dependent parameter implementation of the GIS HALD model.

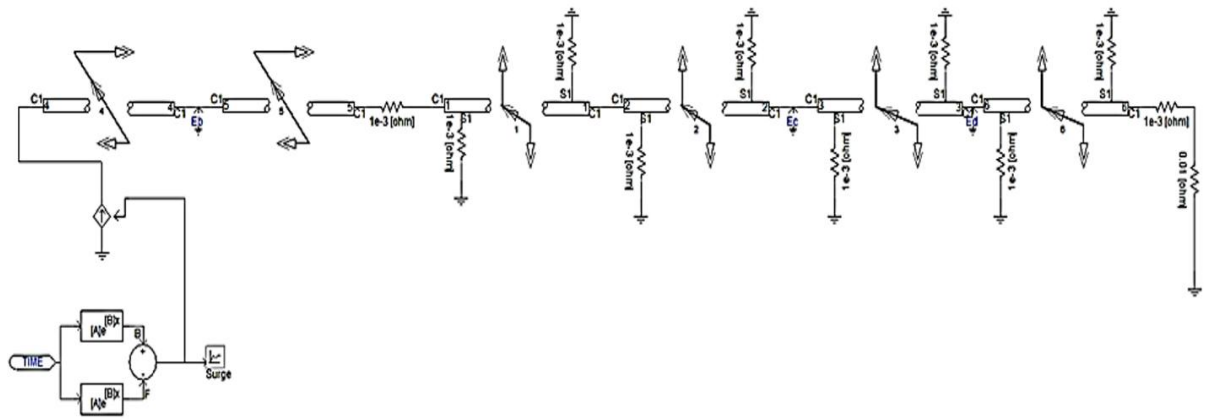

Figure 4. A four-layer co-axial cable Model representing a Gas Insulated Substation in PSCAD.

Transient Ground Potential Rise (TGPR) tests were performed at three locations (with reference to Figure 2) 0.5 m , 1 m and 1.5 m away from point A along the conductor inside the GIS metallic enclosure.

Figure 5, shows the comparison between TGPR (Transient Ground Potential Rise) waveforms data computed by the Electro-Magnetic Field (PEEC) with the HALD (Cable Circuit Theory) model at mid-points (1 m away from point A along the conductor inside the GIS metallic enclosure) which is the fault location.

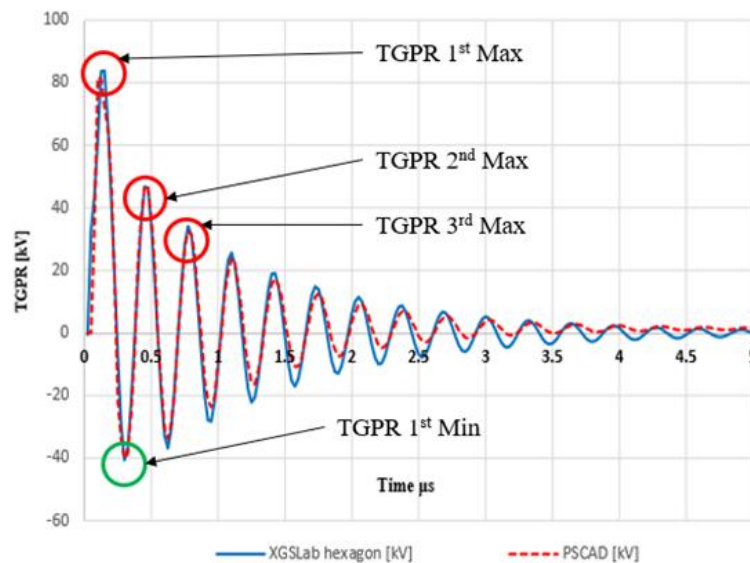

Figure 5. TGPR waveform characteristics at the middle of the enclosure (fault location) with XGSLab and PSCAD software.

The maximum values of the TGPR waveform at 0.5 m away from point A along the conductor inside the GIS metallic enclosure with various related cycles are shown in Table 2. Inspection of Table 2 reveals that the average percentage error between the results obtained from the two models is less than 4%. Higher values can only be observed after the 5th cycle of the TGPR waveform.

Table 2. Measured TGPR values at 0.5m away from point A (refer to Figure 2) along the GIS.

	EMF [kV]	HALD [kV]	Error [%]
TGPR 1 st Max.	48.37	47.71	1.40%
TGPR 2 nd Amp.	33.90	33.81	0.26%
TGPR 3 rd Amp.	25.37	25.92	2.12%
TGPR 4 th Amp.	18.78	19.89	5.54%
TGPR 5 th Amp.	14.12	15.24	7.33%
TGPR 6 th Amp.	10.85	11.66	6.95%
Avg. Error [%]		3.93%	

Figure 6 shows the maximum values of the TGPR waveform 1.5 m away from point A along the conductor inside the GIS metallic enclosure. Although the simulated voltage waveform from the HALD approach attenuates faster due to the very short physical length of the model, the computed results are in good agreement.

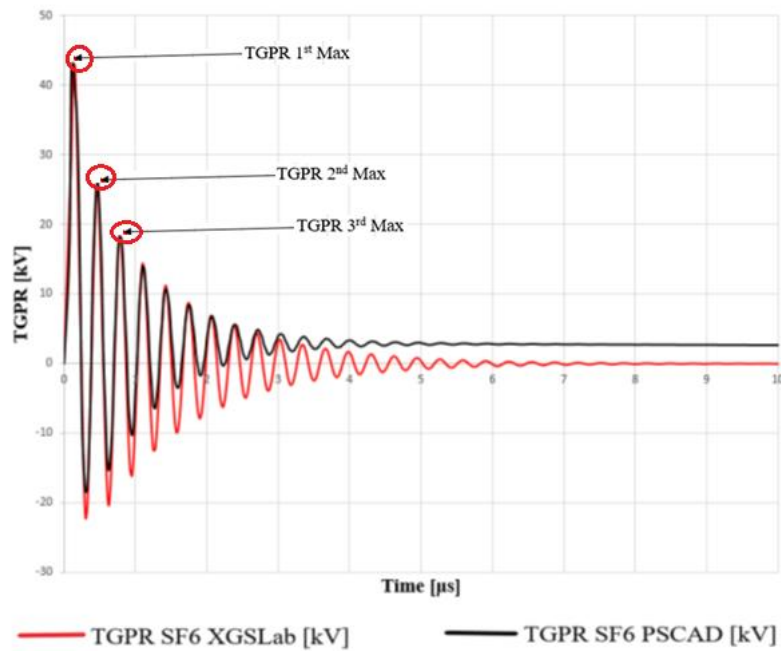

Figure 6. TGPR waveforms at 1.5 m away from point A (Refer to Fig 2) along the GIS length.

The corresponding maximum values of the TGPR waveforms of Fig 6 with various related cycles are shown in Table 3 which reveal that as a whole the average percentage error between the computed results is still below 4.0%.

Table 3. Measured TGPR values at 1.5m away from point A (refer to Figure 2) along the GIS.

	EMF [kV]	HALD [kV]	Error [%]
TGPR 1 st Max.	42.87	43.22	0.80%
TGPR 2 nd Amp.	24.66	25.92	4.84%
TGPR 3 rd Amp.	18.34	18.15	1.09%
TGPR 4 th Amp.	14.40	13.96	3.15%
TGPR 5 th Amp.	11.22	10.68	5.04%
TGPR 6 th Amp.	8.70	8.43	3.21%
Avg. Error [%]		3.02%	

Further computation of other types of transient phenomena within the GIS enclosure at 0.5 m, 1 m and 1.5 m distances along the GIS length away from point A (refer to Figure 2) were carried out using EMF and HALD models. Data for these cases is presented elsewhere [12].

4. Conclusion

The work of this paper has identified a proper modelling technique for evaluation of a GIS simplified model transient response due to a certain fault condition. It has proven that a simplified model emphasizes the focus on the fundamental aspects of the system and physical phenomenon without unnecessary complexities. Also, by establishing an accurate modelling procedure for the simplified model, the work has led to a better understanding of the underlying principles, enabling the development a solid foundation of knowledge. Strictly from a modelling perspective, understanding the applicability and limitations of the simplified model has provided insights into the conditions under which it is valid.

As a whole, components of the GIS under investigation are successfully modelled in both XGSLab and PSCAD software. The close correlation of results from both models, namely EMF and HALD, under lightning surge with double exponential waveforms confirm the proposed HALD approach can be used as a benchmark for verification of results obtained from other available software under various test conditions. Furthermore, the proposed model reduces time and eliminates costs associated with experimentation.

Numerical instabilities and reflections are avoided in the HALD model by considering the matching impedance to have the same value as the computed total impedance of the system; also, by selecting an appropriate simulation time step for short lengths of GIS.

The average percentage error between the results obtained from the two approaches in XGSLab and PSCAD software is less than 4%. Higher error values are recorded after the 5th cycle of the TGPR waveform.

Finally, the work so far reveals that due to the complexity of the system and associated physical phenomenon the proposed modelling is not a one-step process. However, the formulated hypotheses will pave the way for future studies both theoretical and empirical for a complex configuration of GIS.

Acknowledgment

Authors are grateful to Dr. Roberto Andolfato from SINT Engegneria for provision of XGSLab software and technical support.

Conflict of interest

There is no conflict of interest for this study.

References

- [1] Rahmani, S.; Razi-Kazemi, A.A. Investigation of very fast transient over voltages in gas insulated substations. In Proceedings of 2015 2nd International Conference on Knowledge-Based Engineering and Innovation (KB EI), Tehran, Iran, 5–6 November 2015, <https://doi.org/10.1109/KB EI.2015.743608>.
- [2] CIGRE working group D1.03. Very fast transient overvoltage (VF TO) in Gas Insulated UHV Substations. Available online: <https://e-cigre.org/publication/519-very-fast-transient-overvoltages-vfto-in-gas-insulated-uhv-substa> (accessed on 3 February 2016).
- [3] IEC 60071-4. Insulation co-ordination–Part 4: Computational guide to insulation co-ordination and modelling of electrical networks Standard. Available online: <https://standards.globalspec.com/std/833998/IEC/TR%2060071-4> (accessed on 12 May 2016).
- [4] Ruan, W.; Dawalibi, F.P.; Ma, J. Study of Transient Ground Potential Rise in Gas-Insulated Substation during Fault Condition using Electromagnetic Field Theory Approaches. Available online: https://www.sestec.h.com/pdf/User2000_A.pdf (accessed on 8 February 2016).
- [5] Xin, W.; Zhang, G.; Yuan, W.; Wu, J.; Geng, Y. Calculation of transient electromagnetic fields generated during switching operation in power substation by the method of moment and superposition principle. In Proceedings of 2013 2nd International Conference on Electric Power Equipment - Switching Technology

- (ICEPE-ST), Matsue, Japan, 20–23 October 2013, <https://doi.org/10.1109/icepe-st.2013.6804385>.
- [6] Szewczyk, M.; Kutorasinski, K.; Wronski, M.; Florkowski, M. Full-Maxwell Simulations of Very Fast Transients in GIS: Case Study to Compare 3-D and 2-D-Axisymmetric Models of 1100 kV Test Setup. *IEEE Trans. Power Deliv.* **2016**, *32*, 733–739, <https://doi.org/10.1109/tpwr.2016.2527823>.
- [7] Florkowska, A.; Zydron, P.; Jackowicz-Korczynski, A. Electric Field Modelling in Gas-Insulated Substation for Analysis of Conditions for Partial Discharge Phenomena. *Acta Phys. Pol. A* **2015**, *128*, 319–325.
- [8] CIGRE Working Group C4.501. Guideline for Numerical Electromagnetic Analysis Method and its Application to Surge Phenomena. June 2013. Available online: <https://e-cigre.org/publication/543-guideline-for-numerical-electromagnetic-analysis-method-and-its-application-to-surge-phenomena> (accessed on 11 November 2017).
- [9] Challagondla, N. K.; Thummapal, D. The study of very fast transient over voltages (VFTO) for the project of 400/220kV GIS substation with one and half circuit breaker configuration. In Proceedings of 2016 IEEE International Conference on High Voltage Engineering and Application (ICHVE), Chengdu, China, 19–22 September 2016, <https://doi.org/10.1109/ICHVE.2016.7800605>.
- [10] *BPA Electromagnetic Transient Program*. EMPT theory book. Bonneville Power Administration: Portland, OR, USA, 1994; pp. 354–395.
- [11] XGSLab software package. Available online: <https://www.xgslab.com/xgslab/general> (accessed on 8 September 2016).
- [12] Mureşan, A. Electromagnetic Modelling Technique Applied to Transient Behavior of Gas Insulated Substation. PhD Thesis, Technical University of Cluj-Napoca, Cluj-Napoca, Romania, 2020.